



MOTOMA®

Power into the Future

USER MANUAL



6.2KW
Hybrid Inverter

Table Of Contents

ABOUT THIS MANUAL	1
Purpose	1
Scope	1
SAFETY INSTRUCTIONS	1
INTRODUCTION	2
Features	2
Basic System Architecture	3
Product Overview	4
INSTALLATION	5
Unpacking and Inspection	5
Preparation	5
Mounting the Unit.....	5
Battery Connection	6
AC Input/Output Connection	7
PV Connection.....	9
Final Assembly	12
Communication Connection	13
Dry Contact Signal.....	13
OPERATION	14
Power ON/OFF	14
Operation and Display Panel.....	14
LCD settings.....	16
Faults/Warnings Reference Code	32
CLEARANCE AND MAINTENANCE FOR ANTI-DUST KIT	33
Overview	33
Clearance and Maintenance.....	33
SPECIFICATIONS	34
TROUBLE SHOOTING	35
Appendix I: Parallel function	36
Appendix II: BMS Communication Installation	53
Appendix III: The CT Operation Guide	56
Appendix IV: The Wi-Fi Operation Guide.....	58

ABOUT THIS MANUAL

Purpose

This manual describes the assembly, installation, operation, and troubleshooting of this unit. Please read this manual carefully before installation and operation. Keep this manual for future reference.

Scope

This manual provides safety and installation guidelines as well as information on tools and wiring.

SAFETY INSTRUCTIONS



WARNING: This chapter contains important safety and operating instructions. Read and keep this manual for future reference.

1. Before operating the unit, carefully read all instructions and warning labels on the device, the batteries, and all relevant sections of this manual.
2. CAUTION – To minimize the risk of injury, only charge deep-cycle lead-acid rechargeable batteries. Using other battery types may cause them to burst, leading to personal injury and damage.
3. Do not take the unit apart. If service or repairs are needed, bring it to a qualified service center. Improper reassembly could result in electric shock or fire hazards.
4. To avoid electric shock, disconnect all wiring before performing any maintenance or cleaning. Simply turning off the unit does not eliminate this risk.
5. CAUTION – Installation of this device with batteries should only be performed by qualified personnel.
6. NEVER charge a battery that is frozen.
7. For optimal performance of this inverter/charger, ensure you select the correct cable size according to the specified requirements. Proper operation depends on this.
8. Exercise extreme caution when using metal tools near batteries. Dropping a tool could cause sparks or short circuits, potentially leading to explosions.
9. Follow the installation procedures carefully when disconnecting AC or DC terminals. Refer to the INSTALLATION section of this manual for detailed instructions.
10. Fuses are included to protect the battery supply from over-current conditions.
11. GROUNDING INSTRUCTIONS – This inverter/charger must be connected to a permanently grounded wiring system. Make sure to comply with all local codes and regulations during installation.
12. NEVER allow the AC output and DC input to short circuit. Do NOT connect to the mains power if there is a DC input short circuit.
13. Warning! Only qualified service technicians should service this device. If problems continue after consulting the troubleshooting guide, return the inverter/charger to your local dealer or service center for repair.

INTRODUCTION

This is a versatile inverter that integrates the features of an inverter, solar charger, and battery charger, providing continuous power backup in one unit. The detailed LCD screen allows users to easily configure settings and access buttons for options like battery charging current, prioritizing AC or solar charging, and setting acceptable input voltage according to various needs.

Features

- Pure sine wave
- Power factor range: 0.9 lead- 0.9 lag
- Battery independent design
- Enhance MPPT solar charge controller up to 9000 WATTS
- Maximum Solar Charge Current 130A
- Compatible with Lithium-ion battery
- Reserved communication port for BMS
- Communication Interface USB/RS232/RS485/CAN/Dry contact
- User-friendly 4.3" HMI LCD
- Built-in Wi-Fi for mobile monitoring (App is available) and support OTA firmware
- Programmable multiple operation modes: Grid-tie, off-grid and grid-tie with backup
- PV, Grid and Battery energies generation and consumption data available
- Dual output for smart load management
- Increased feed power to 8200W
- Feeding power into Grid
- Parallel operation up to 9 units
- Built-in 2 MPP trackers
- Maximum PV input current 22Ax2
- External CT sensor to guarantee 100% self-consumption
- Built-in anti-dust kit

Basic System Architecture

This hybrid PV inverter can supply power to connected devices by using energy from the solar panels, the utility grid, and the battery.

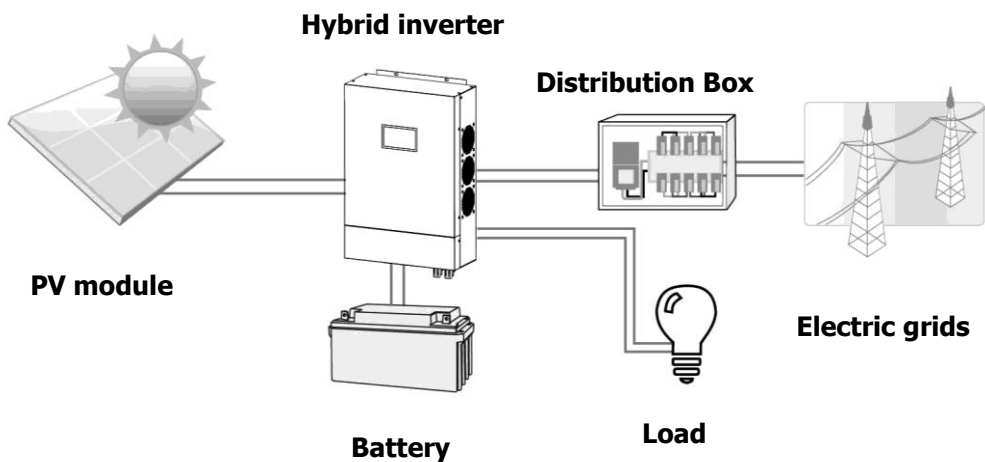
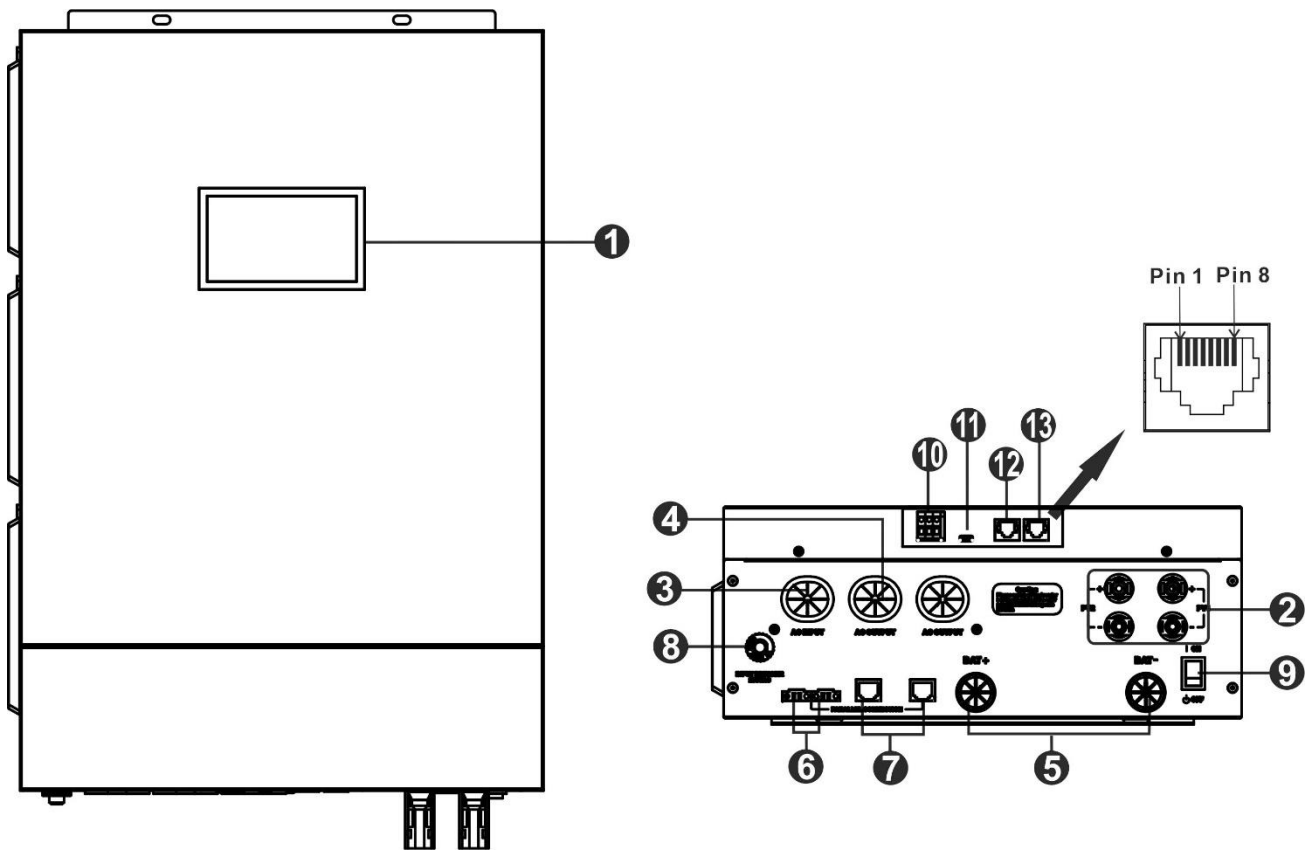

Figure 1 Basic Hybrid PV System Overview

This hybrid inverter is designed to provide continuous power from solar panels (PV modules), batteries, and the utility grid, depending on various power conditions. When the PV modules' MPP input voltage falls within the specified acceptable range (refer to the specifications for details), the inverter can supply power to the grid and charge the battery simultaneously. Never connect the solar panel's positive and negative terminals to the ground. Refer to Figure 1 for a basic diagram of a typical solar system using this hybrid inverter.

Product Overview



NOTE: For parallel installation and operation, please check *Appendix I*.

1. Touchable HMI screen
2. PV connectors
3. AC input connectors
4. AC output connectors (Load connection)
5. Battery connectors
6. Current sharing port
7. Parallel communication port
8. Circuit breaker
9. Power switch
10. Dry contact
11. USB communication port
12. RS-232 communication port
13. BMS communication port: CAN, RS-485, or RS-232

INSTALLATION

Unpacking and Inspection

Before installing, please check the unit carefully. Make sure that nothing inside the package is damaged. The package should contain the following items:

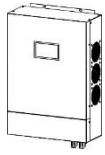

Inverter



User manual



Communication cable



Parallel communication cable (Optional)



Current sharing cable (Optional)

Preparation

Before connecting all the wires, please remove the bottom cover by unscrewing the four screws as shown below.

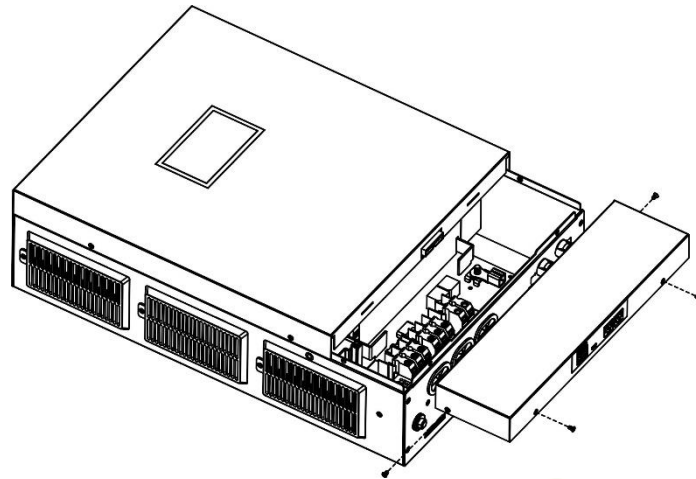

Mounting the Unit

- Please keep the following points in mind when choosing the installation location:
- Avoid mounting the inverter on flammable building materials.
- Install it on a sturdy surface.
- Position the inverter at eye level so the LCD display can be easily viewed at all times.
- Ensure the surrounding temperature is between -10°C and 50°C for optimal performance.
- The inverter should be installed vertically on the wall as recommended.
- Maintain the clearances from other objects and surfaces as illustrated in the diagram on the right to allow proper heat dissipation and provide enough space for wire removal.

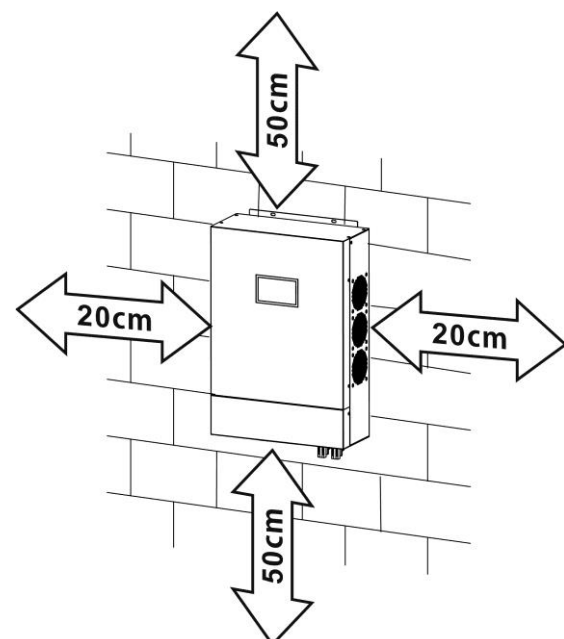

SUITABLE FOR MOUNTING ON CONCRETE OR OTHER NON-COMBUSTIBLE SURFACES ONLY.

Mount the unit using three screws. It is advisable to use M4 or M5 screws.

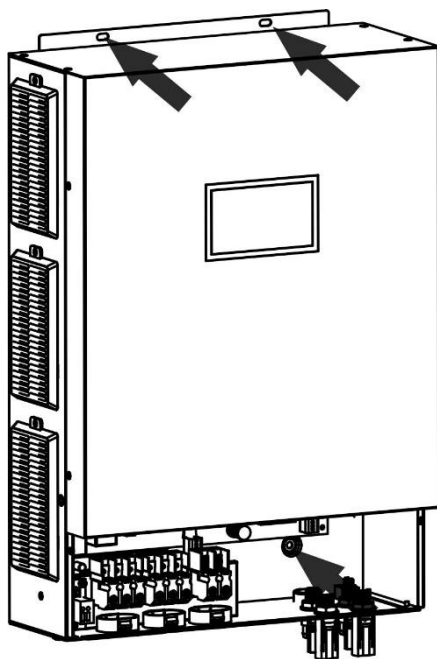

Battery Connection

CAUTION! To ensure safe operation and meet regulatory requirements, it is recommended to install a dedicated DC over-current protection device or disconnect switch between the battery and the inverter. While a disconnect device may not be necessary in certain cases, over-current protection is always required. Please consult the typical current values in the table below to determine the appropriate fuse or breaker size.

WARNING! Trained professionals should carry out all electrical wiring.

WARNING! For safe and effective system performance, it is essential to use the correct cables for connecting the battery. To minimize the risk of injury, please use the specified cable and terminal sizes as indicated below.

Ring terminal:

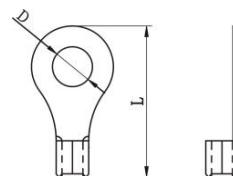

Recommended battery cable and terminal size:

Model	Typical Amperage	Battery Capacity	Wire Size	Ring Terminal			Torque Value
				Cable mm ²	Dimensions		
					D (mm)	L (mm)	
6.2K	142A	200AH	1*2AWG or 2*6AWG	28	6.4	42.7	2~3 Nm

Please follow the steps below to connect the battery:

1. Assemble the battery ring terminal according to the recommended battery cable and terminal size.
2. Insert the battery cable's ring terminal flatly into the inverter's battery connector, ensuring the nuts are tightened to a torque of 2-3 Nm. Verify that the polarity is correctly matched at both the battery and the inverter/charger, and that the ring terminals are securely fastened to the battery terminals.

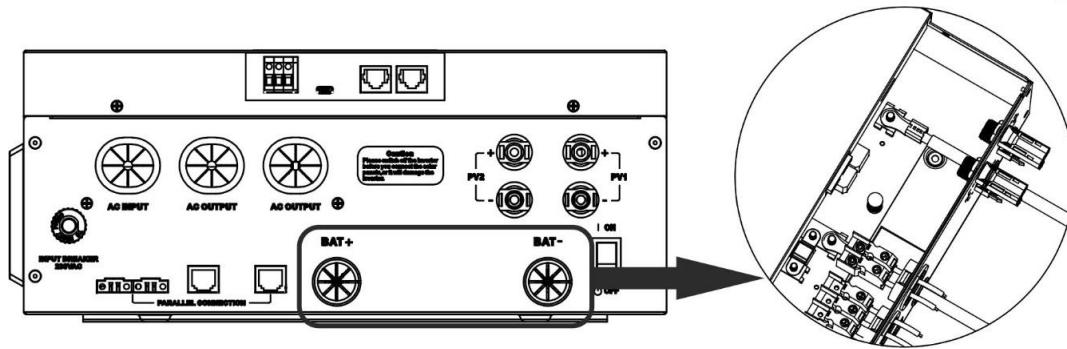

WARNING! Risk of Electric Shock
 Installation should be carried out carefully because of the high voltage from batteries connected in series

CAUTION! Do not insert any material between the flat surface of the inverter terminal and the ring terminal, as this may cause overheating.
CAUTION! Do not apply any anti-oxidant substances to the terminals before securely tightening the connections.
CAUTION! Before completing the final DC connection or closing the DC breaker/disconnector, ensure that the positive (+) terminal is connected to the positive (+) terminal and the negative (-) terminal is connected to the negative (-) terminal.

AC Input/Output Connection

CAUTION!! Before connecting to the AC input power source, please install a **separate** AC breaker between the inverter and the AC input power source. This will ensure the inverter can be securely disconnected during maintenance and fully protected from overcurrent of the AC input.

CAUTION!! There are two terminal blocks with "IN" and "OUT" markings. Please do NOT misconnect input and output connectors.

WARNING! All wiring must be performed by qualified personnel.

WARNING! System safety and efficient operation require the use appropriate cable for the AC input connection. To reduce the risk of injury, please use the proper recommended cable size as below.

Suggested cable requirement for AC wires

Model	Gauge	Torque Value
6.2KW	8 AWG	1.4~ 1.6 Nm

Please follow these steps to connect the AC input/output:

1. Before connecting the AC input/output, ensure that the DC protector or disconnector is turned off.
2. Strip 10mm of insulation from all eight conductors. Then, trim the phase L and neutral conductors by 3mm.
3. Insert the AC input wires into the terminal block following the indicated polarities, and securely tighten the terminals.
4. screws. Be sure to connect PE protective conductor (⊕) first.
 ⊕ → **Ground (yellow-green)**
L → **LINE (brown or black)**
N → **Neutral (blue)**

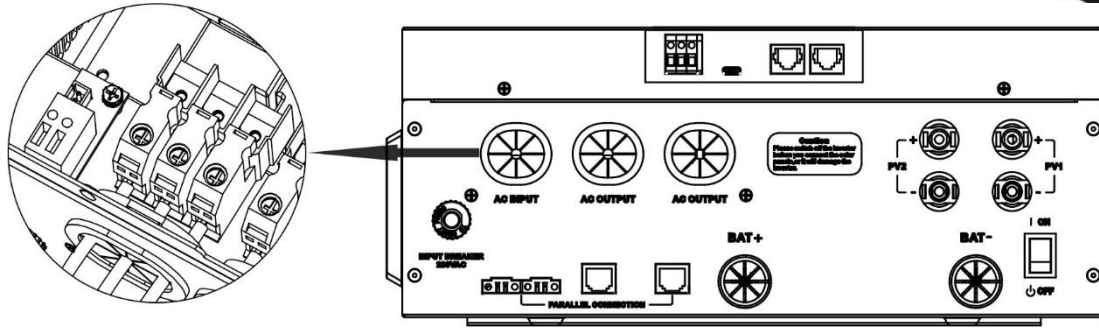

WARNING: Make sure the AC power source is unplugged before trying to hardwire it to the device.

- Then, insert AC output wires according to polarities indicated on the terminal block and tighten terminal screws. Be sure to connect PE protective conductor (⊕) first.

- ⊕ → **Ground (yellow-green)**
- L1 → **LINE (brown or black)**
- N1 → **Neutral (blue)**
- L2 → **LINE (brown or black)**
- N2 → **Neutral (blue)**

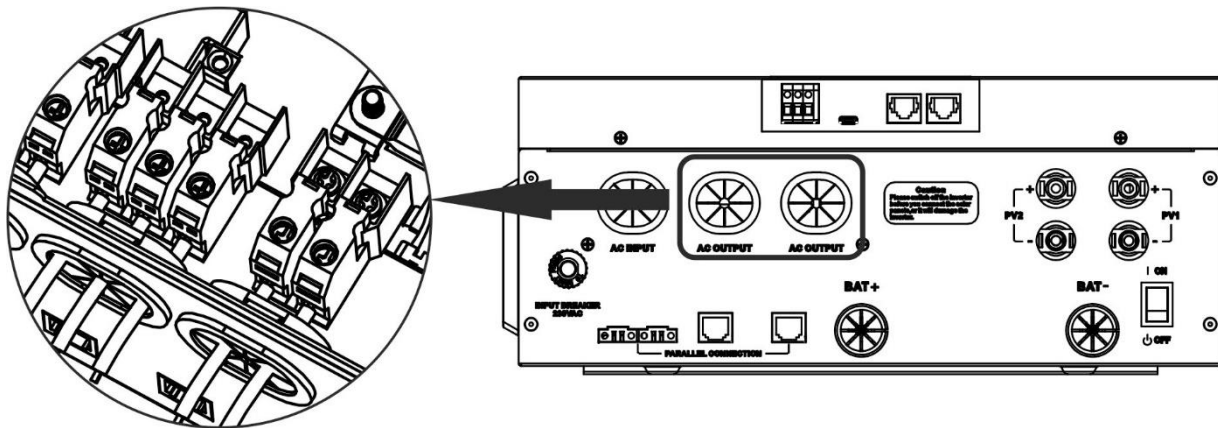

- Ensure that the wires are firmly attached.

CAUTION: Important

Make sure to connect the AC wires with the correct polarity. Reversing the L and N wires can lead to a utility short circuit when these inverters operate in parallel.

CAUTION: Appliances like air conditioners need at least 2 to 3 minutes to restart because this allows enough time for the refrigerant gas inside the system to stabilize. If a power outage happens and power is restored quickly, it can damage your connected devices. To avoid this, please verify with the air conditioner manufacturer whether the unit has a built-in time-delay feature before installation. If not, the inverter/charger may trigger an overload fault and shut off the output to protect your appliance, but in some cases, internal damage to the air conditioner can still occur.

PV Connection

CAUTION: Prior to connecting the PV modules, ensure that a DC circuit breaker is installed separately between the inverter and the PV modules.

WARNING! All wiring should be carried out by qualified personnel.

WARNING! Always turn off the inverter before connecting the PV modules to prevent damage to the inverter.

WARNING! For system safety and optimal performance, it is crucial to use the correct cables for connecting the PV modules. To minimize the risk of injury, please use the recommended cable sizes as specified below.

Model	Typical Amperage	Cable Size	Torque
6.2KW	22A*2	12AWG	2.0~2.4Nm

PV Module Selection:

When selecting proper PV modules, please be sure to consider below parameters:





1. Open circuit Voltage (Voc) of PV modules not exceeds max. PV array open circuit voltage of inverter.
2. Open circuit Voltage (Voc) of PV modules should be higher than min. battery voltage.

Solar Charging Mode	
INVERTER MODEL	6.2KW
Max. PV Power	9000W
Max. PV Array Open Circuit Voltage	500 Vdc
PV Array MPPT Voltage Range	85~430Vdc
MPP Number	2
Max. PV Current	22A*2

Please follow the steps below to implement the PV module connection:

1. Assemble the provided PV connectors with PV modules by following steps.

Components for PV connectors and Tools:

Female connector housing	
Female terminal	
Male connector housing	
Male terminal	
Crimping tool and spanner	

Prepare the cable and follow the connector assembly process:

Strip one cable 8 mm on one side, and be careful NOT to nick conductors.

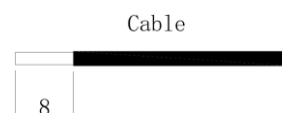

Insert the striped cable into the female terminal and crimp the female terminal as shown below.



Insert the assembled cable into the female connector housing as shown below.

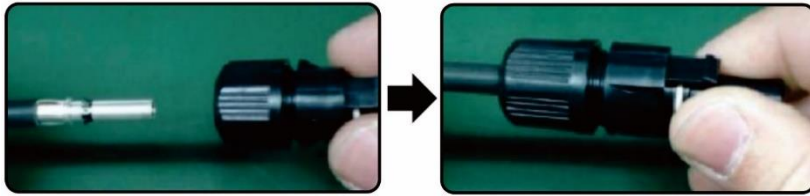

Insert the striped cable into the male terminal and crimp the male terminal as shown below.



Insert the assembled cable into the male connector housing as shown below.

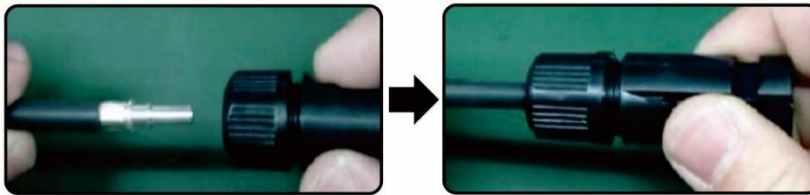

Reference insertion force: $\leq 50\text{N}$

Reference withdrawal force: $\geq 50\text{N}$

Then, use a spanner to screw the pressure dome tightly to the female and male connectors as shown below.



The reference Nut cap locking force is 2.0~2.5Nm.

- Verify the correct polarity of the connection cable from the PV modules and the PV input connectors. Then, connect the positive (+) end of the connection cable to the positive (+) terminal of the PV input connector. Similarly, connect the negative (-) end of the connection cable to the negative (-) terminal of the PV input connector.

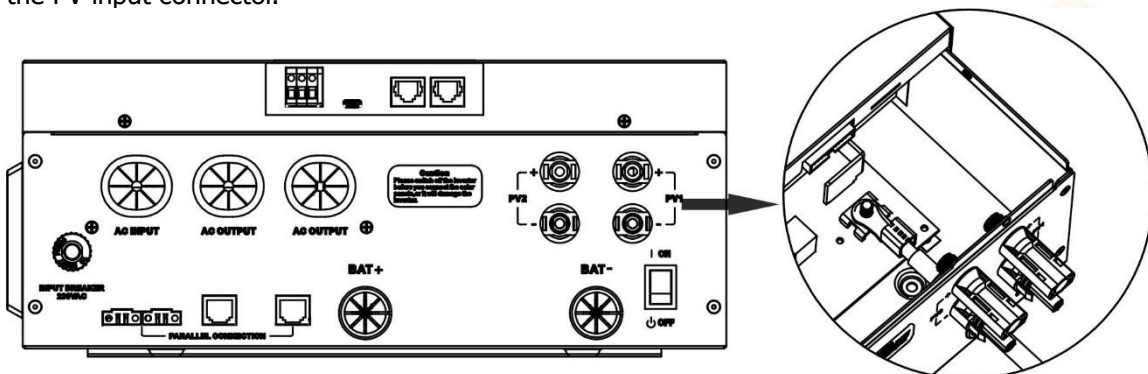

Recommended PV Module Configuration

Solar Panel Spec (reference)	Solar input 1	Solar input 2	Q'ty of panels	Total input power
	Min in series:4pcs,per input; max in series:12pcs,per input			
-250Wp	4pcs in series	X	4pcs	1000W
-Vmp:30.7Vdc	X	4pcs in series	4pcs	1000W
-Imp:8.3A	12pcs in series	X	12pcs	3000W
-Voc:37.7Vdc	X	12pcs in series	12pcs	3000W
-Isc:8.4A	6pcs in series	6pcs in series	12pcs	3000W
-Cells:60	6pcs in series,2 strings	X	12pcs	3000W
	X	6pcs in series ,2 strings	12pcs	3000W
	8pcs in series	8pcs in series	16pcs	4000W
	8pcs in series ,2 strings	X	16pcs	4000W
	X	8pcs in series ,2 strings	16pcs	4000W
	9pcs in series	9pcs in series	18pcs	4500W
	9pcs in series ,2 strings	X	18pcs	4500W
	X	9pcs in series ,2 strings	18pcs	4500W
	10pcs in series ,1 strings	10pcs in series ,1 strings	20pcs	5000W
	10pcs in series ,2 strings	X	20pcs	5000W
	X	10pcs in series ,2 strings	20pcs	5000W
	12pcs in series ,1 strings	12pcs in series ,1 strings	24pcs	6000W
	12pcs in series ,2 strings	X	24pcs	6000W
	X	12pcs in series ,2 strings	24pcs	6000W
	7pcs in series ,2 strings	7pcs in series ,2 strings	28pcs	7000W
	8pcs in series ,2 strings	8pcs in series ,2 strings	32pcs	8000W
	9pcs in series ,2 strings	9pcs in series ,2 strings	36pcs	9000W

Solar Panel Spec (reference)	Solar input 1	Solar input 2	Q'ty of panels	Total input power
-630Wp	X	4pcs in series	4pcs	2520W
-Vmp:41.6Vdc	X	5pcs in series	5pcs	3150 W
-Imp:15.16A	X	6pcs in series	6pcs	3780W
-Voc:48.8Vdc	X	7pcs in series	7pcs	4410W
-Isc:16.62A	X	8pcs in series	8pcs	5040W
	X	9pcs in series	9pcs	5670W
	5pcs in series	5pcs in series	10pcs	6300W
	6pcs in series	6pcs in series	12pcs	7560W
	7pcs in series	7pcs in series	14pcs	8820W
	8pcs in series	7pcs in series	15pcs	9450W

Solar Panel Spec (reference)	Solar input 1	Solar input 2	Q'ty of panels	Total input power
- 585Wp	X	4pcs in series	4pcs	2340W
- Vmp: 43.3Vdc	X	5pcs in series	5pcs	2925 W
- Imp: 13.52A	X	6pcs in series	6pcs	3510W
- Voc: 52.4Vdc	X	7pcs in series	7pcs	4095W
- Isc: 14.00A	X	8pcs in series	8pcs	4680W
	X	9pcs in series	9pcs	5265W
	5pcs in series	5pcs in series	10pcs	5850W
	6pcs in series	6pcs in series	12pcs	7020W
	7pcs in series	7pcs in series	14pcs	8190W
	8pcs in series	8pcs in series	16pcs	9360W

Final Assembly

Once all the wiring is connected, please reattach the bottom cover by securing it with the four screws as illustrated below.

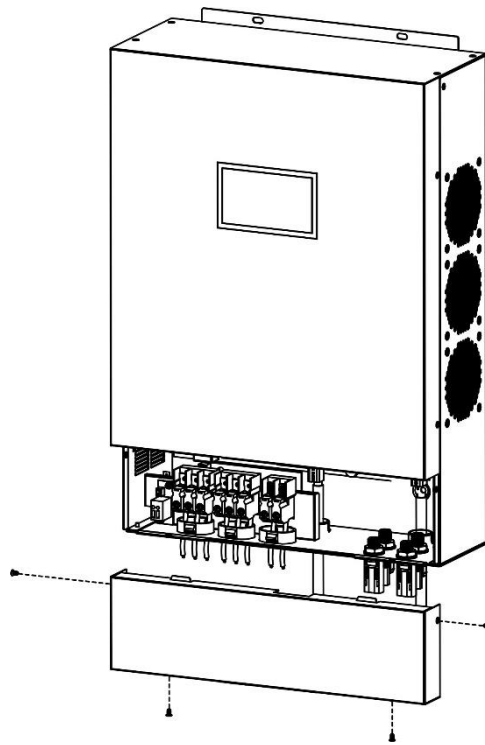

Communication Connection

Serial Connection

Kindly connect the inverter to the PC using the supplied communication cable. Then, download and install the monitoring software from the official website.

Wi-Fi Connection

The Wi-Fi module allows hybrid inverters to communicate wirelessly with the monitoring platform. When used together with the i.Solar APP, which is compatible with both iOS and Android devices, allows users to fully monitor and control their inverters remotely. All data logs and parameters are stored in iCloud. For easy setup and use, please see Appendix IV - The Wi-Fi Operation Guide for more information.

Dry Contact Signal

There is one dry contact (3A/250VAC) available on the rear panel. It could be used to deliver a signal to an external device when the battery voltage reaches a warning level.

Unit Status	Condition		Dry contact port: 		
			NC & C	NO & C	
Power Off	The unit is off, and no output is powered.		Close	Open	
Power On	Output is powered from Utility.		Close	Open	
	Output is powered from a battery or Solar.	When the grid is not available	Battery voltage < Low DC warning voltage	Open	Close
			Battery voltage > Setting value in Charger stop or battery charging reaches the floating stage	Close	Open
		When the grid is available	Battery voltage < Setting value in Charger start	Open	Close
Battery voltage > Setting value in Charger stop or battery charging reaches the floating stage			Close	Open	

OPERATION

Power ON/OFF

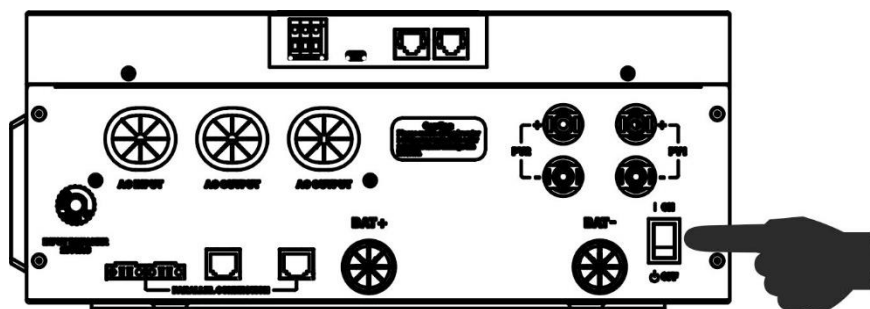

After correctly installing the unit and securely connecting the batteries, just press the On/Off switch to power on the device.

Operation and Display Panel

Features a 4.3" touchscreen HMI LCD that shows comprehensive information about the inverter. Provides a clear view of the inverter's operating status and energy flow, making it simple to understand the inverter's current mode of operation.

Home page

- Top Menu Bar: displays key system details such as the Brand Model, BMS Connection Status, Parallel Status, Wi-Fi Connection Status, Mute Status, Warning/Fault Messages, and the current time.
- Center of the Screen: offers a real-time summary of energy distribution, showing Solar, Grid, Battery, and Load usage. Arrows illustrate the direction of energy flow and operational status.

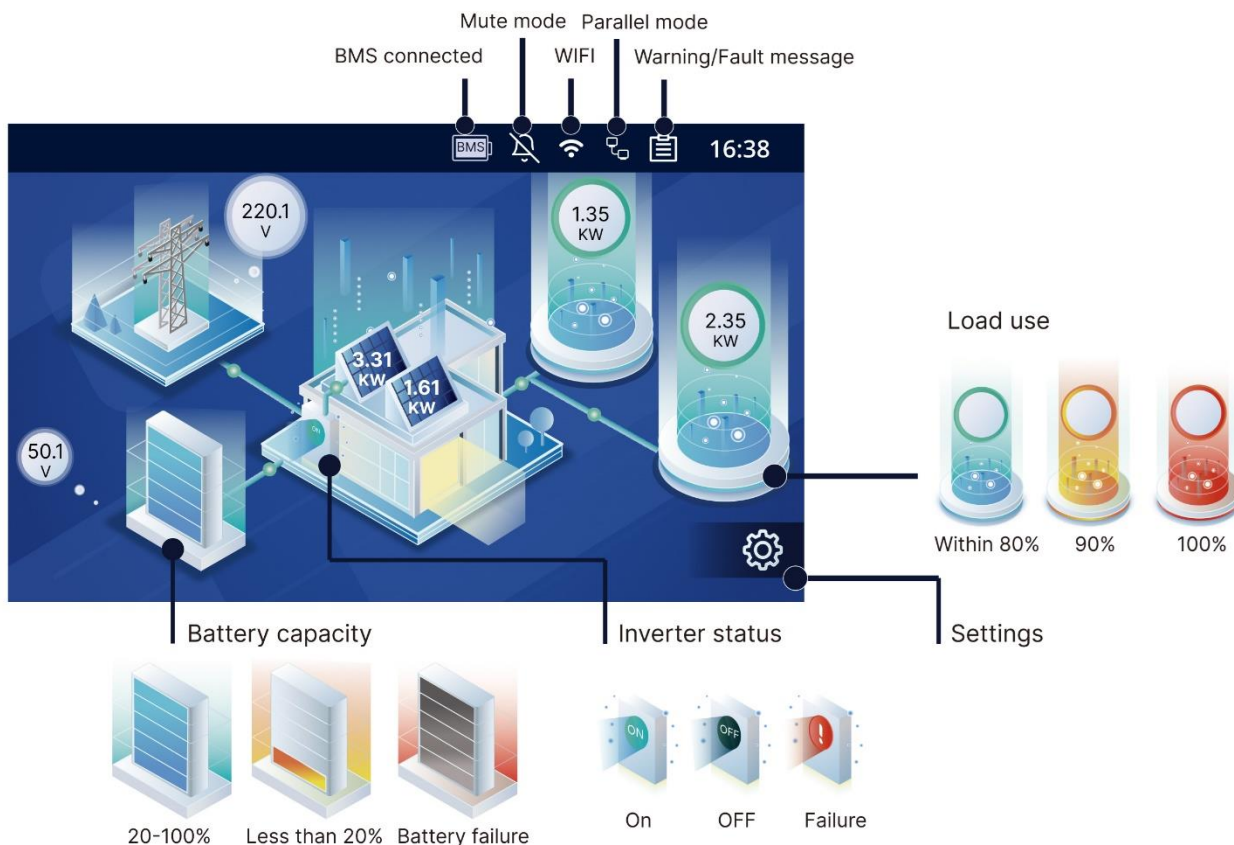

Basic information



Grid direction
 Grid power out
 Grid power in

Select the Mains, Battery, Load 1, and Load 2 icons to see detailed information such as grid voltage, frequency, and direction; battery voltage, charging/discharging current, power, and state of charge (SOC); as well as output voltage, current, and power for Loads 1 and 2.

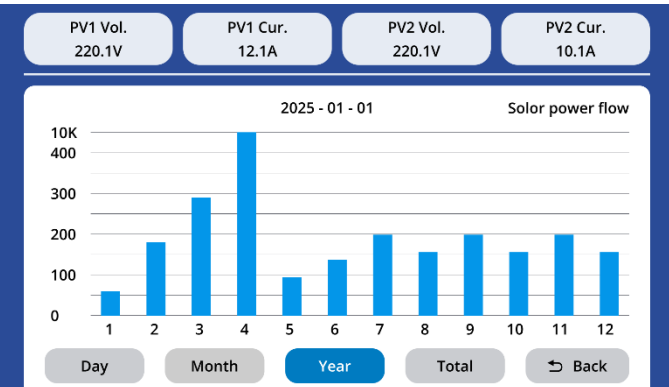

Tap the PV icon to see real-time readings of PV1 voltage, PV1 current, PV2 voltage, and PV2 current. Additionally, a graph will show daily, monthly, and yearly PV power data.

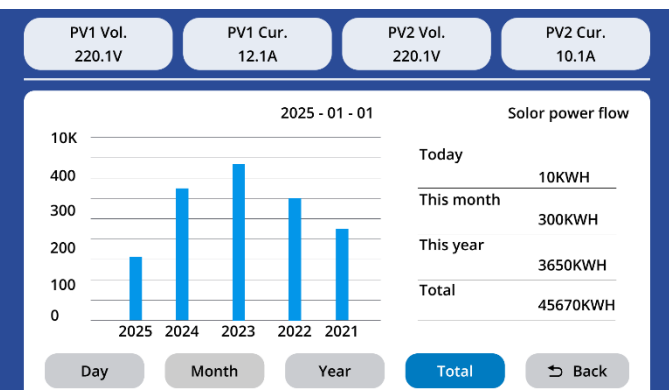

Tap **Total** to access historical solar data. The main section displays a power generation chart, and daily, monthly, yearly, and overall statistics are presented on the right side.

LCD settings

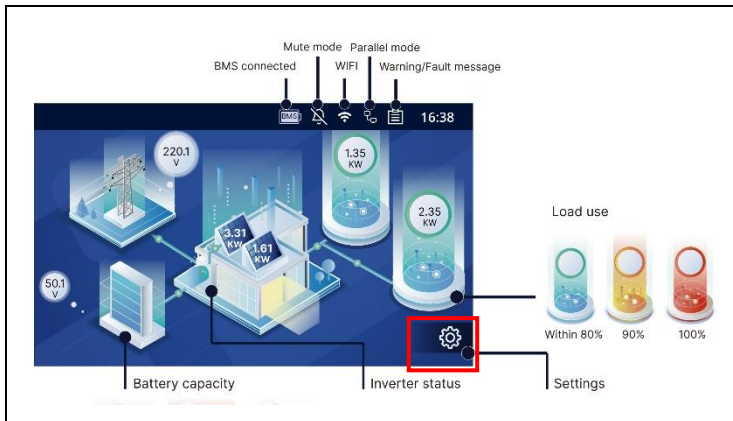

Tap  to access the LCD settings.

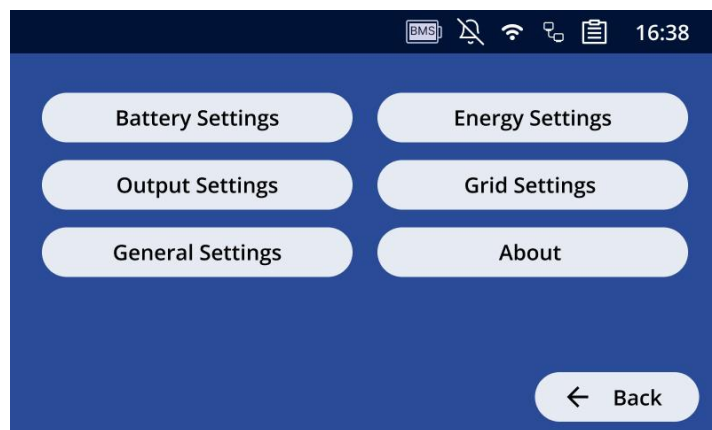

The following page lets you adjust battery options, system power settings, output and its configurations, grid parameters, general preferences, and view system details in the "About" section.

Battery Settings

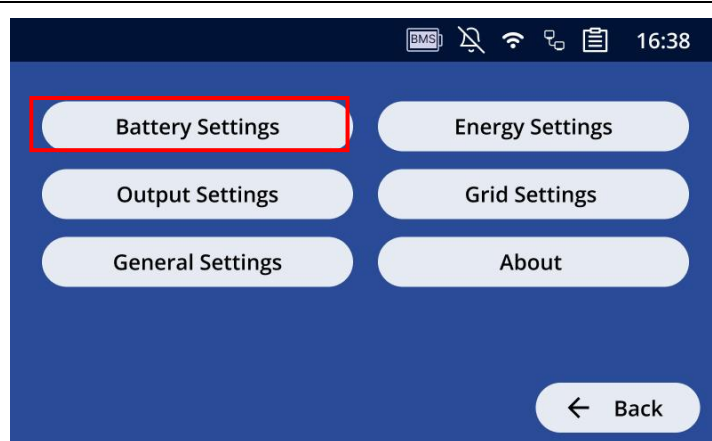

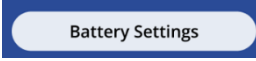
Tap  to access the battery settings interface, where you can organize and configure the battery type, charging options, and discharging options.

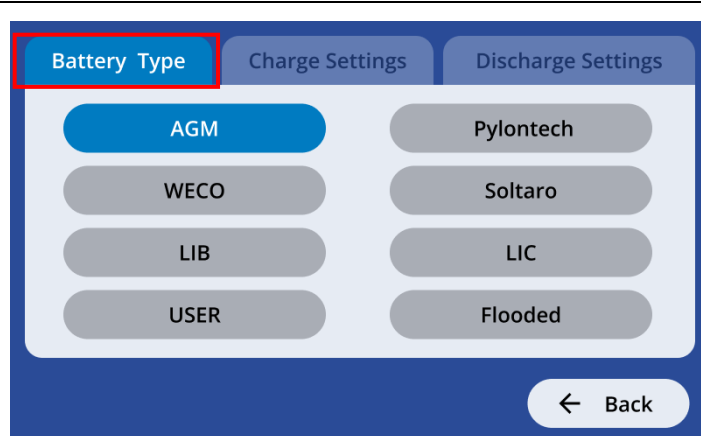

The standard battery type is AGM. When using Pylontech, WECO, Soltaro, LIB, or LIC batteries, a BMS communication cable must be connected. In this case, the charging voltage and current are controlled by the BMS and cannot be modified by the user.

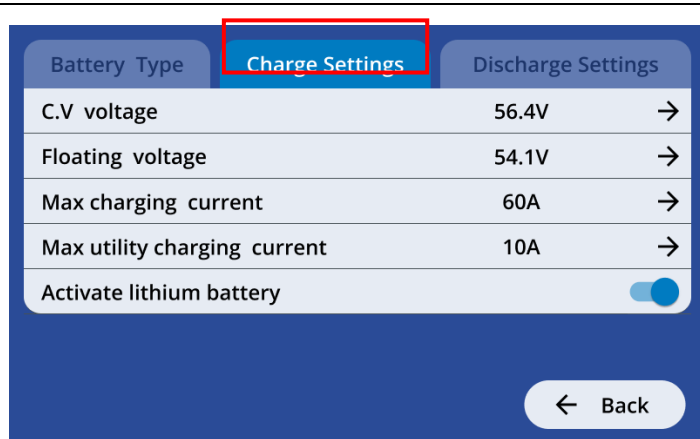

For user-defined settings, parameters such as charging voltage and current can be adjusted. However, once connected to a BMS, the constant voltage (C.V.), floating voltage, and maximum charging current are controlled by the BMS and cannot be modified by the user.

Adjustable ranges include:

- C.V. and Floating Voltage: 48V to 60V, adjustable in 0.1V steps
- Maximum Charging Current: 10A to 130A, adjustable in 10A steps
- Maximum Utility Charging Current: 2A, and from 10A to 120A

Lithium Battery Activation: When enabled, the lithium battery will be activated whenever the inverter is powered on.

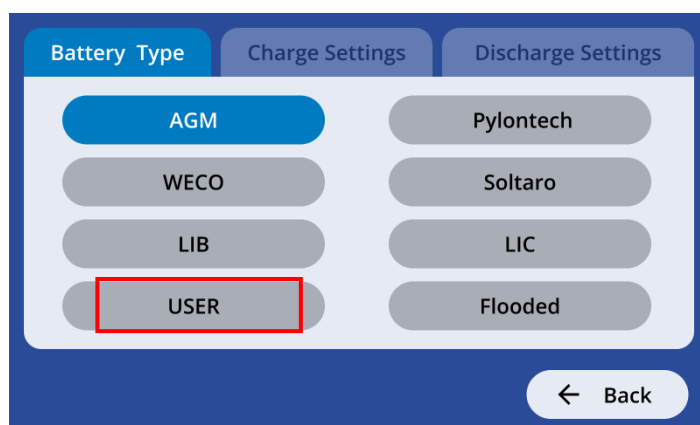

When the battery type is set to USER mode, the low DC cutoff battery voltage can be adjusted within the range of 40.8V to 52V, with increments of 0.1V.

Once the low DC cutoff battery voltage is linked to the BMS, the adjustable range spans from 0% to 80%.

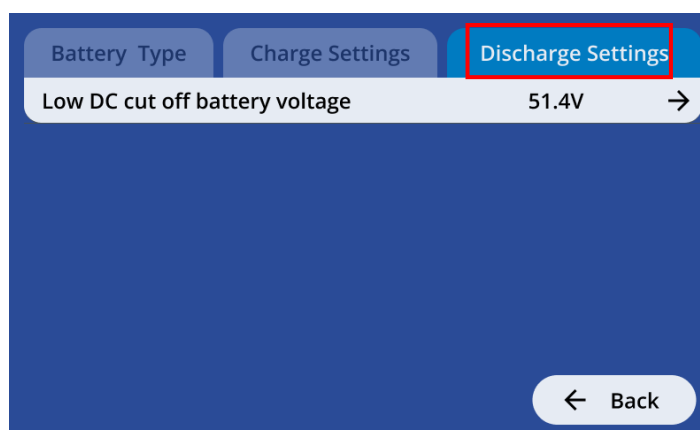

Output Settings

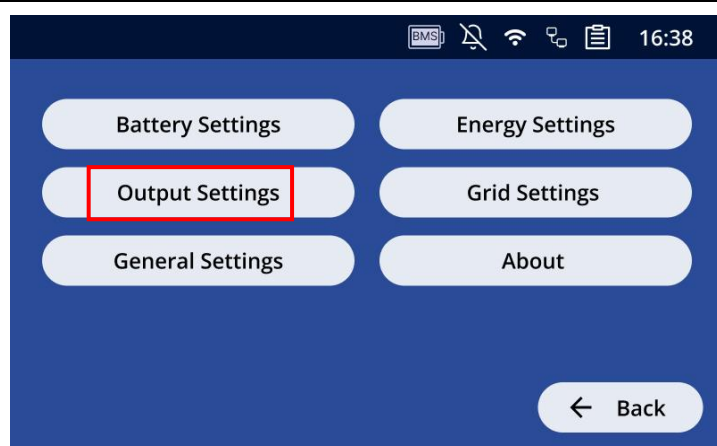

Tap **Output Settings** to configure the output rated voltage, rated frequency, single or parallel output, L2 output control, and output restart settings for specific conditions.

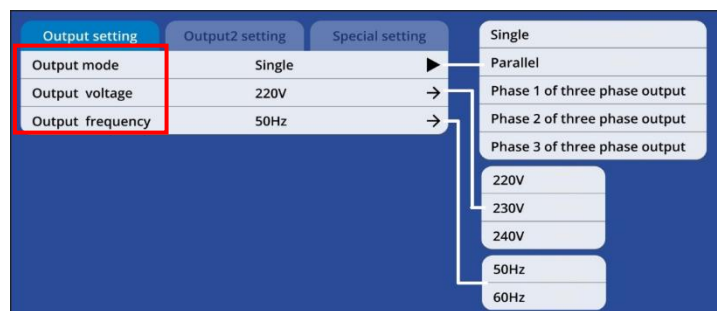

Output setting

Output mode:

- **Single:** single operation
- **Parallel:** parallel operation
- **Phase X of three-phase output:** Set to three-phase S operation, where X represents one of the three phases.

NOTE: This setting can only be available in standby mode (switch off)

Output voltage selections: 220V, 230V, 240V

Output frequency selections: 50Hz, 60Hz



Output 2 setting

Low battery cutoff for output 2

When the second output is enabled (it is disabled by default), if the battery voltage drops below the specified value, the L2 output will be turned off.

The voltage setting range is from 40.8V to 52.0V, adjustable in 0.1V increments.

After connecting to the BMS, the setting range changes to 0% to 95%, with adjustments in 5% increments.

Battery low on output2

When the second output is activated, if the battery voltage exceeds the specified threshold, the L2 output will be turned on. The voltage can be set between 40.8V and 60.0V, with increments of 0.1V.

After connecting to the BMS, the setting range changes to 5% to 95%, with adjustments in 5% steps.

Battery Discharge Duration for Output 2

In Battery mode, the discharge time for the

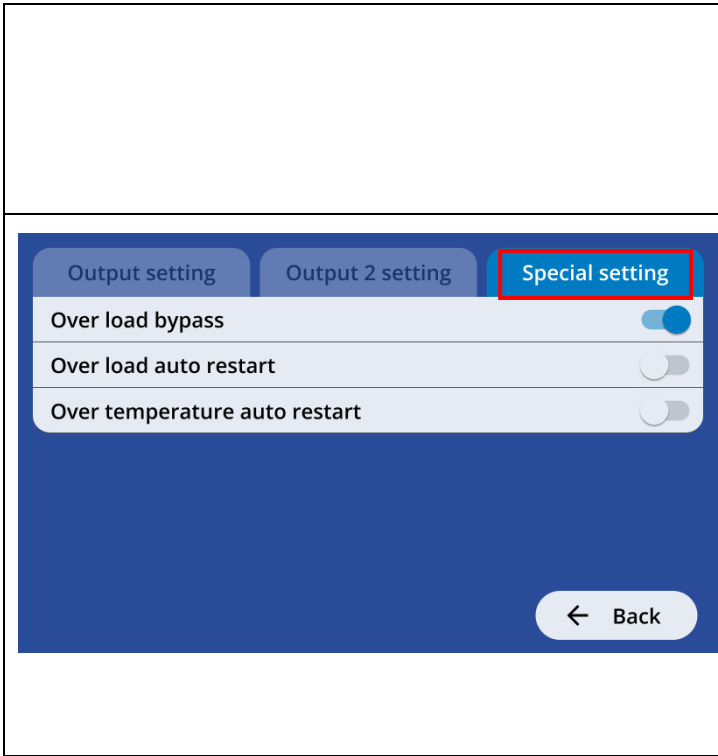

second output can be set between 0 and 999. If the value exceeds 995, the output will be turned off.
 Schedule for L2 output ON: 00:00 to 24:00
 Schedule for L2 output OFF: 00:00 to 24:00

Special setting

Overload bypass

When enabled, the inverter will switch to mains power mode if an overload occurs while operating in battery mode.

Overload auto-restart

When enabled, the inverter will automatically attempt to restart up to 3 times after an overload event.

Over temperature auto restart

When enabled, the inverter will automatically attempt to restart up to 3 times after detecting an over-temperature condition.

Grid Settings

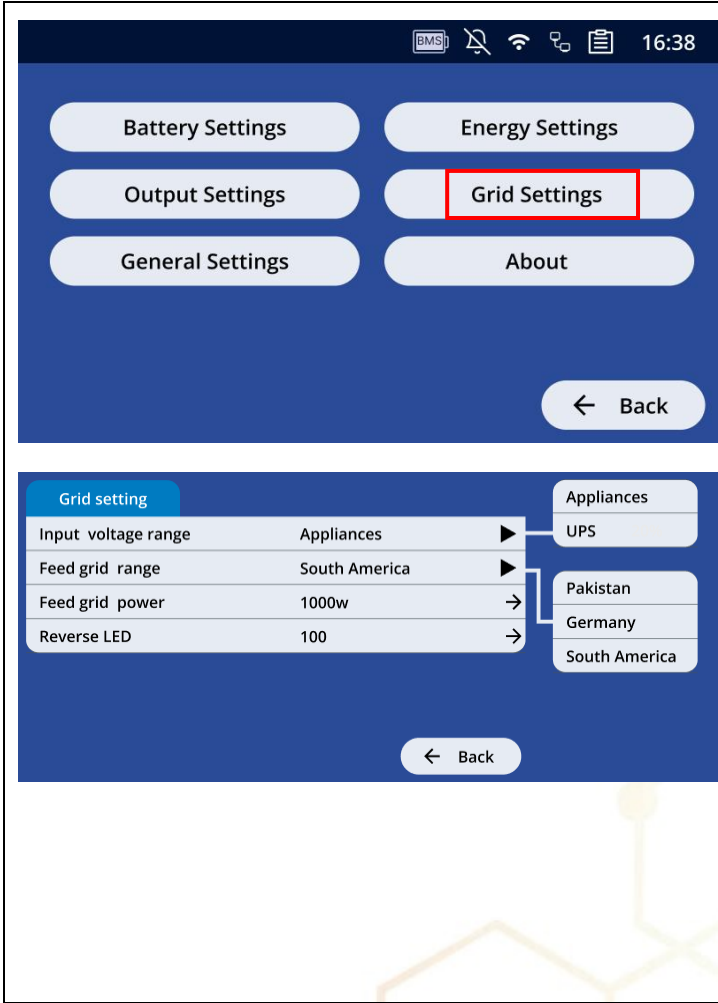

Tap **Grid Settings** to set the width ranges of the input and feeder.

Input voltage range:

Appliances: accept input grid voltage range of 90~280VAC

UPS: Accept input grid voltage range of 170~280VAC

Feed grid range:

Pakistan: Acceptable feeder voltage range is 184~264.5VAC, and the feeder frequency is 47.5~51.5Hz

Germany: Acceptable feeder voltage range is 195.5~253VAC, and the feeder frequency is 49~51Hz

South America: Acceptable feeder voltage range is 184~264.5VAC, and the feeder frequency is 57~62Hz

Feed grid power Limit: Feed the grid the maximum power.

Reverse LED: When the meter's reverse light is on, adjust this parameter, and the setting range is 0~300.

General Settings

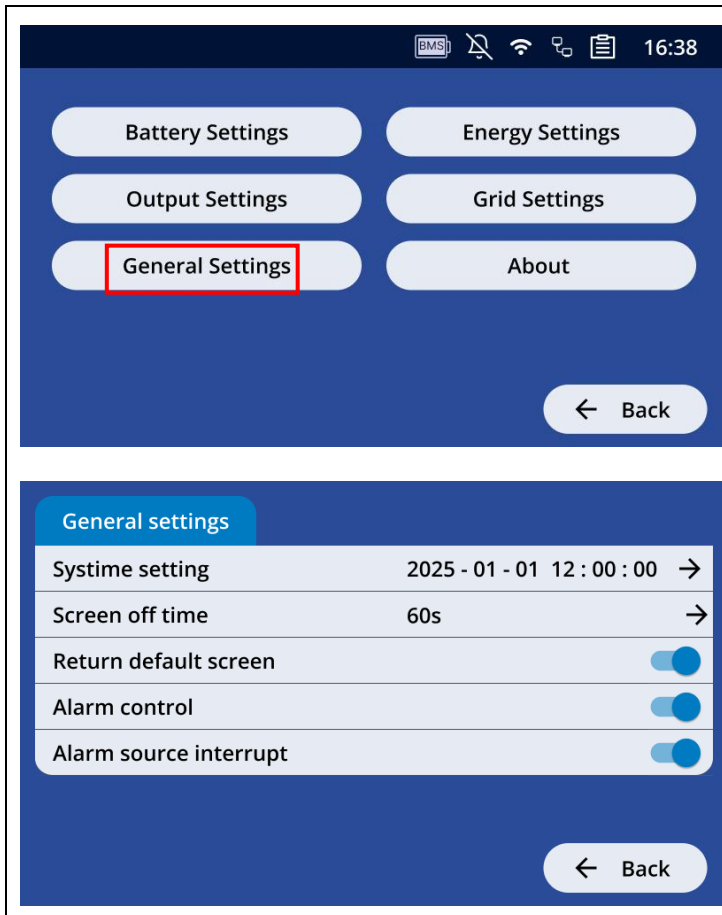

Tap **General Settings** to enter the general settings, where you can set up System Time, Screen off time, Mute, and Return to the Default Interface Time.

Energy settings

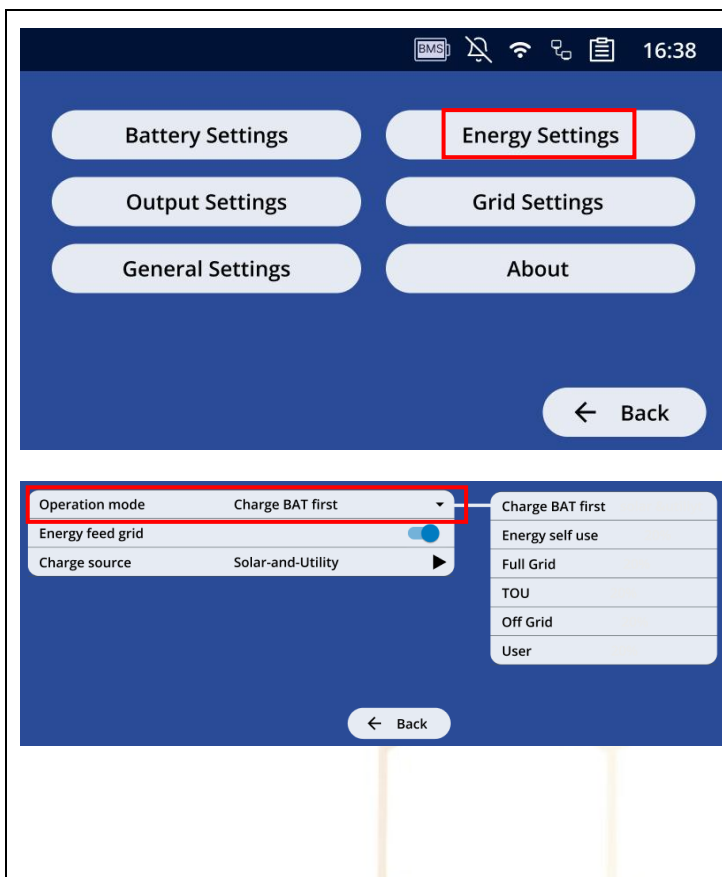

Tap **Energy Settings** to categorize and set up the operation mode, the grid energy feedback, and other functions in each mode.

(Charge BAT First mode by default)

There are six main working modes for the energy storage system: Charge BAT first, Energy Self Use, Off-Grid, TOU, Full-Grid, and User.

Charge the BAT in the first operation mode

Applicable scenario: It prioritizes battery charging during periods of sufficient PV generation and stable grid power. This stored energy is then used to power loads during outages. Any excess PV energy after battery charging is used to power loads directly or fed to the grid. However, if grid power is unavailable, PV energy is first used to power loads, with any surplus then used for battery charging.

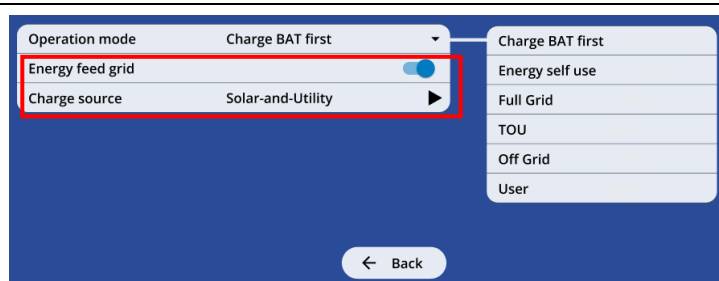

Energy feed grid:

If it is set to enabled, solar energy is allowed to feed into the grid, solar energy is not allowed to feed into the grid

Charge source:

Solar first: Set this option to solar power first. When there is no solar power, the utility will supply power.

Solar and Utility: Solar and Utility supply power together.

Only solar: Allow solar power only

Schematic diagram of charge priority

When the power generated by the PV system surpasses the total demand from battery charging and loads, the extra energy is initially used to charge the battery. Any leftover energy after that supplies backup loads, and any additional surplus is sent to the grid to support household loads.

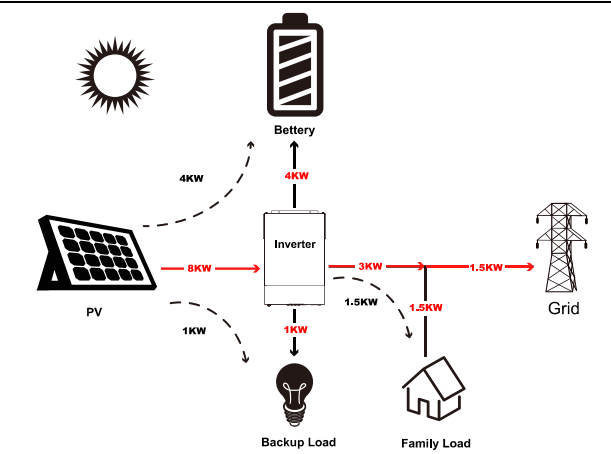

When the power generated by the PV system is insufficient to meet the total demand from battery charging and loads, the PV output is initially used to charge the battery, followed by supplying the backup loads. Any additional backup and household load requirements are then supplied by the grid.

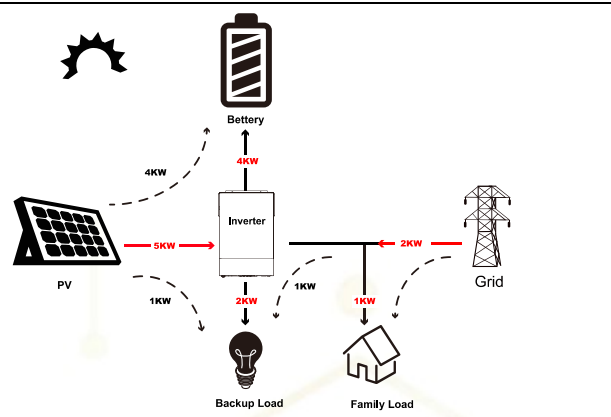

When the solar (PV) generation is not enough to charge the battery, the PV output is solely dedicated to charging the battery. In this case, the grid provides power to charge the battery and also supplies electricity to the backup system and household loads.

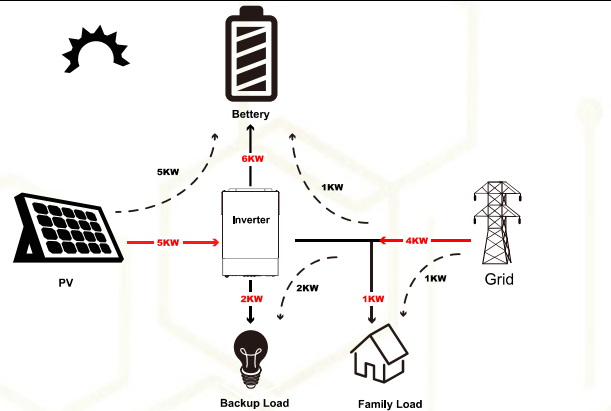

Energy self-use operation mode

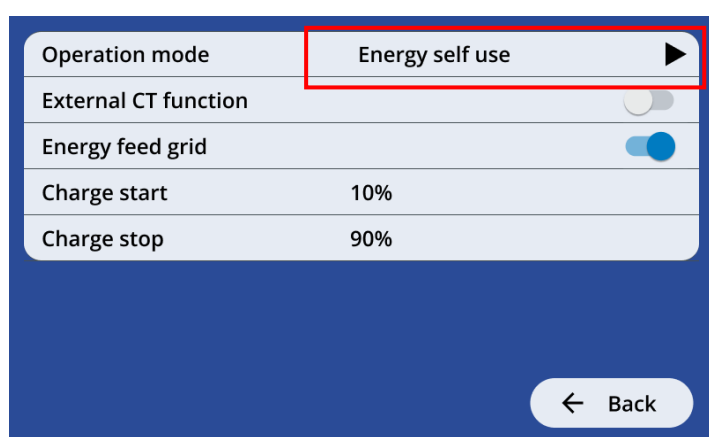

Energy self-use operation mode

Applicable scenario: ideal for areas with high electricity costs and minimal or no feed-in tariffs (FITs). Excess PV energy is stored in a battery, which then powers loads during periods of low or zero PV generation (e.g. Nighttime). This increases PV self-consumption and household energy independence, resulting in savings on electricity consumption.

External CT function:

If it is set to enabled, turn on the external CT function; turn off this function.

Energy feed grid:

If it is set to enabled, solar energy is allowed to feed into the grid, solar energy is not allowed to feed into the grid.

NOTE: After enabling external CT, the energy feed grid will be disabled by default, and user setting is not allowed.

Charge start:

The setting range is 5%~95% when the battery is connected to the BMS, and 44.0V~51.0V when no battery is connected to the BMS.

Charge stop:

The setting range is 10%~100% when the battery is connected to the BMS, and 48.0V~58.0V when no battery is connected to the BMS.

Schematic diagram of maximum spontaneous self-generation (CT is disabled)

When the power generated by the PV system surpasses the total demand from battery charging and backup loads, the power is initially directed to the backup loads, followed by charging the battery. If feeding power back to the grid is allowed, any surplus energy is sent to the grid; if not, the excess power is not fed into the grid.

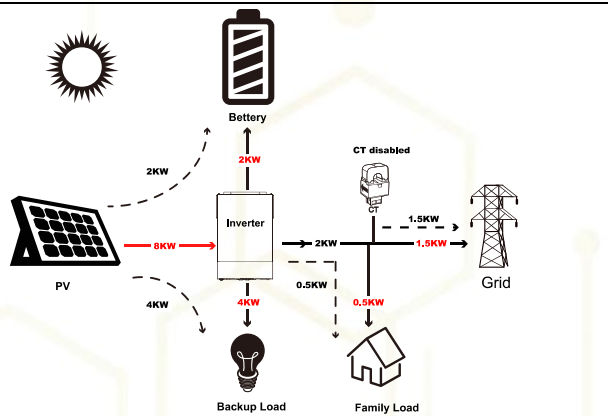

When the power generated by the PV system is less than the total power required for battery charging and backup loads, priority is given to supplying power to the backup loads first, followed by charging the battery. If feeding power back to the grid is allowed, the grid will provide power to charge the battery and meet the household's energy needs.

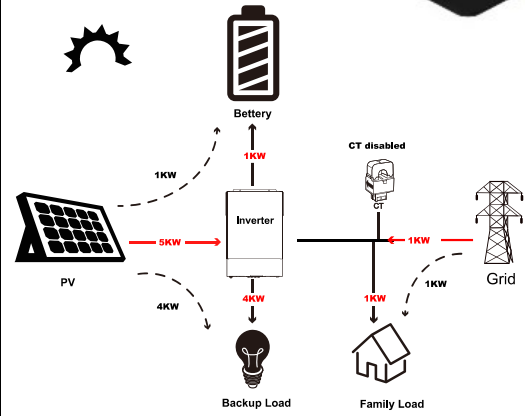

When the PV output is not enough to satisfy the backup load demand, the available PV power is dedicated solely to the backup loads. The battery then provides additional power to the backup loads, while the grid supplies electricity to the household loads.

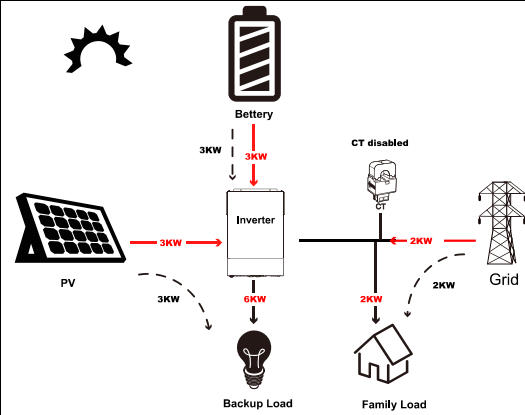

Schematic diagram of maximum spontaneous self-generation (CT is enabled)

When the power generated by the PV system surpasses the total demand of battery charging and backup load, the energy is initially directed to the backup load, followed by charging the battery. Any surplus PV energy will then be used to supply the household load.

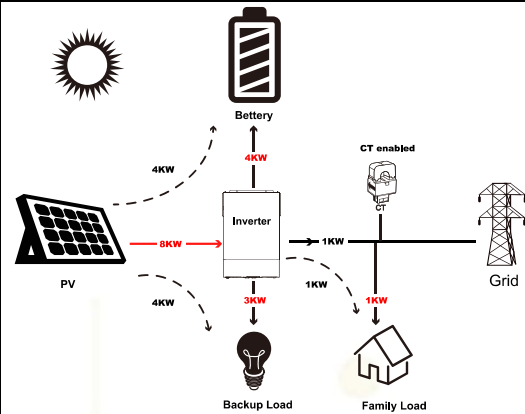

When the power generated by the PV system is insufficient to meet the backup load, the available PV power is dedicated solely to the backup load. The grid supplies the remaining backup load as well as the household load.

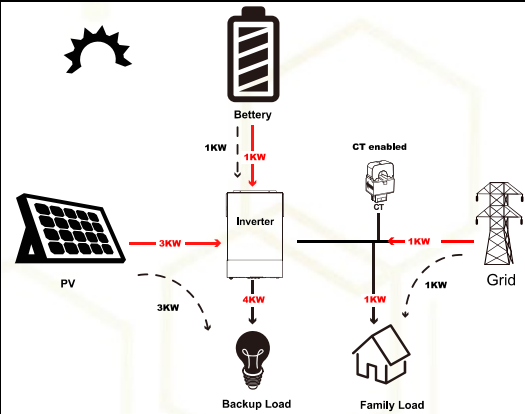

When the solar (PV) output is higher than what is required for battery charging and backup loads, the power is initially directed to the backup loads, followed by charging the battery. Any surplus power is then utilized for household consumption. If the external current transformer (CT) is activated, excess PV energy is not supplied to the grid.

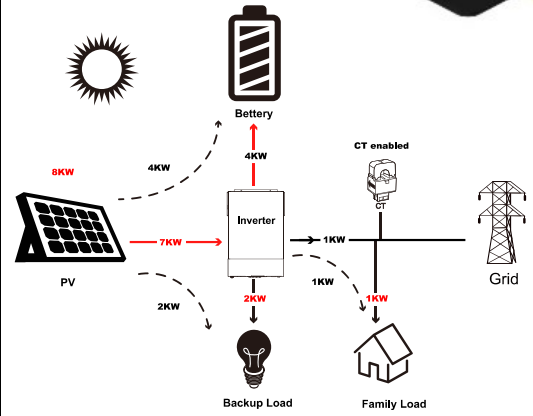

When both the solar (PV) and battery power are low, and the PV generation is insufficient to meet the backup load demand, all the PV power is allocated to the backup load. The grid provides the remaining power needed for the backup load as well as the entire household load.

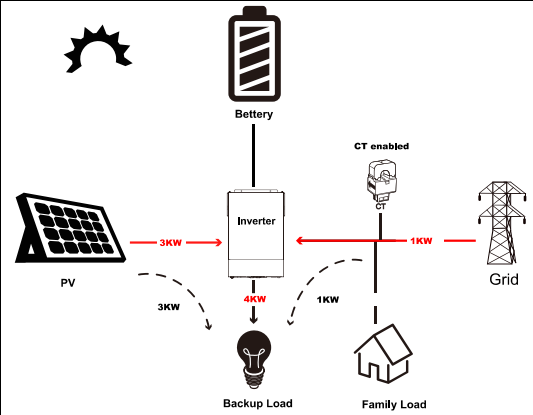

TOU operation mode

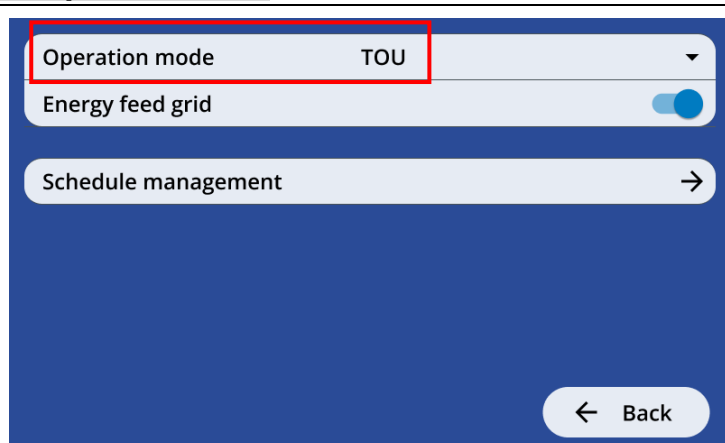

TOU operation mode

Suitable scenario: This Time-of-Use (TOU) mode is ideal for places where electricity prices vary greatly between peak and off-peak times. It lets users manually define when to charge and discharge the battery. The system prioritizes charging the battery during low-cost times (such as overnight) and restricts discharging to high-cost periods, helping to reduce electricity costs. During charging intervals, the battery can be charged from the grid. During discharging intervals, the battery supplies power to the loads. Outside the specified discharge times, the battery stays inactive unless set to discharge; in these cases, solar (PV) and grid power directly feed the loads. However, if the grid power fails, the battery will discharge at any time to maintain power.

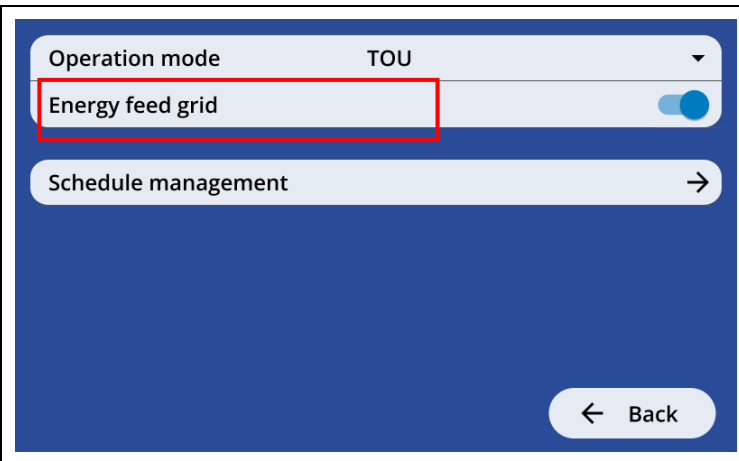

Energy feed grid

If enabled, solar energy can be supplied to the grid; if not, solar energy cannot be supplied to the grid.

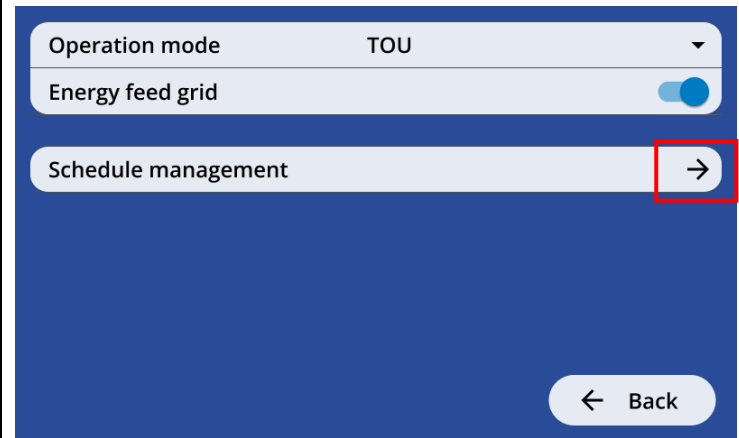

Click the → arrow button next to Schedule Management to access the schedule management interface (setting it to 00:00 means it is always ENABLED).

Charging period

Setting range: 00:00-24:00

First discharge period

Setting range: 00:00-24:00

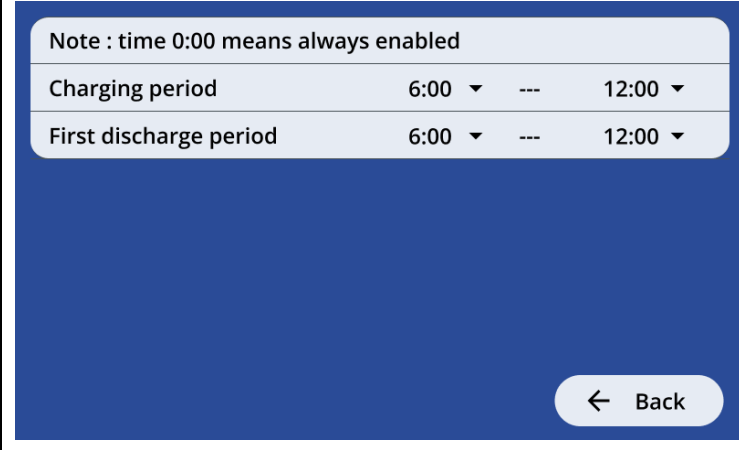

Schematic diagram of TOU

(Charging window 00:00~03:00, discharging window 14:00~24:00)

During the charging period, if the battery's state of charge (SOC) is empty, the battery is charged by the grid, while the grid also supplies power to the household and backup loads.

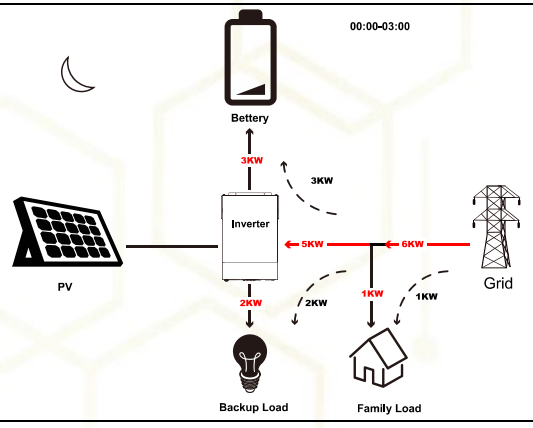

When the battery is fully charged during the charging phase, it will cease charging. At that point, the grid power will supply electricity to both the household and backup loads.

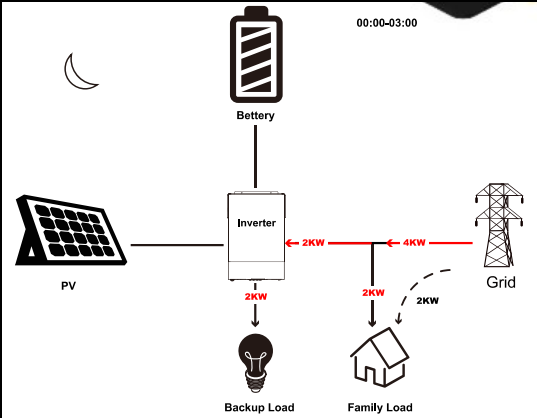

When the system is not charging or discharging, the household and backup loads are supplied by both the grid and the solar panels. If the solar power production is greater than the demand, the surplus energy is used to charge the battery.

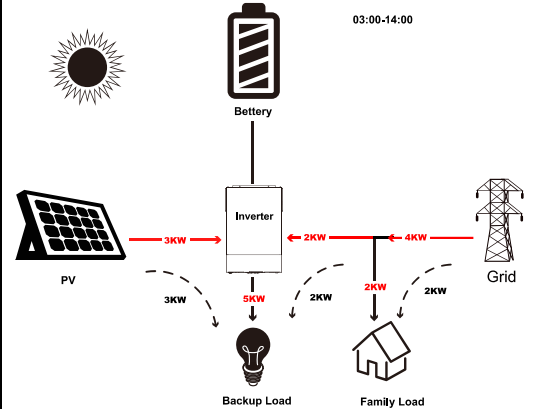

During discharge times, the battery and accessible solar energy provide power to backup loads. If the grid is connected, it will also supply power to the household loads.

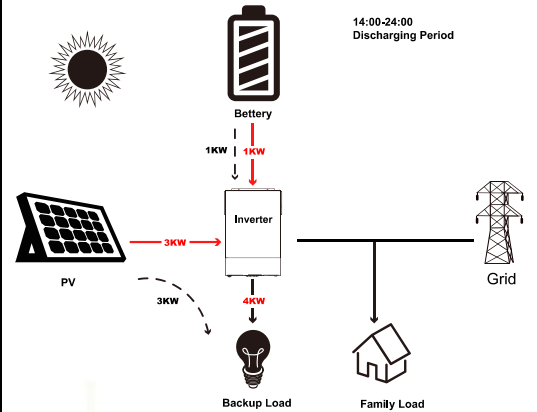

Off-grid operation mode

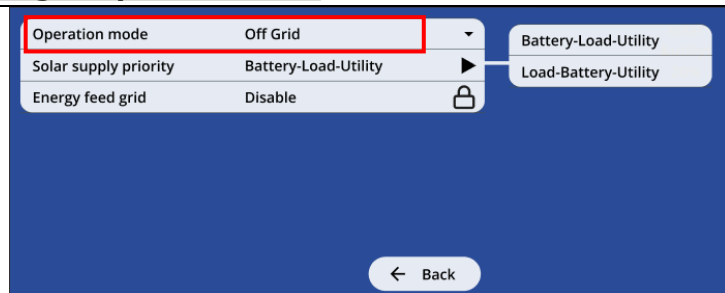

Off-grid operation mode

Applicable scenario: Designed for off-grid or unreliable grid conditions, this system stores solar energy in a battery to supply power to loads when solar generation is low or unavailable. The system prioritizes charging the battery before providing power to the loads. A configurable option allows prioritizing either battery charging or directly powering the loads from solar energy.

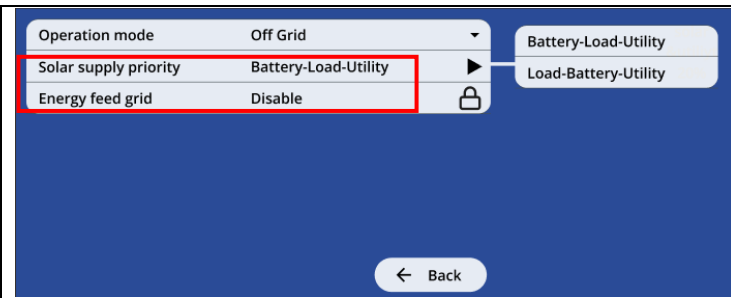

Battery-Load-Utility: Solar power is used to charge the battery first
Load-Battery-Utility: Solar power is used to power the loads first.
Energy feed grid: If it is set to enabled, solar energy is allowed to feed into the grid, solar energy is not allowed to feed into the grid.

Schematic diagram- Off Grid

In bright sunlight, solar power is utilized to charge the battery and supply backup loads, with the option to prioritize either one. Any surplus PV energy is not sent to the grid nor used for household loads; instead, those loads are supplied by the grid.

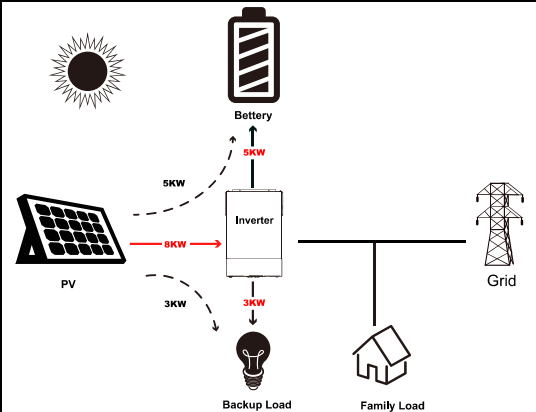

Under low sunlight conditions, solar energy is utilized to charge the battery and power backup loads, with adjustable priority settings. Any deficit in fulfilling the charging or backup load demands is compensated for by electricity from the grid, which also powers household loads.

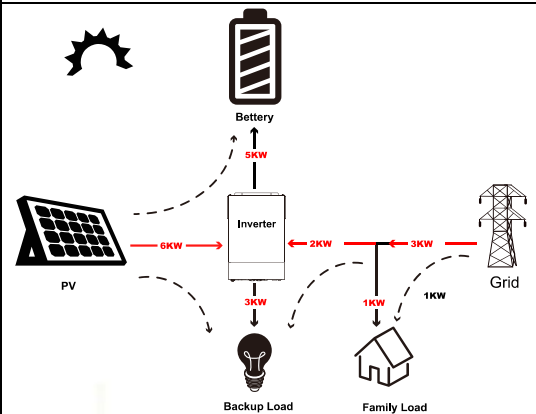

Full-Grid operation mode

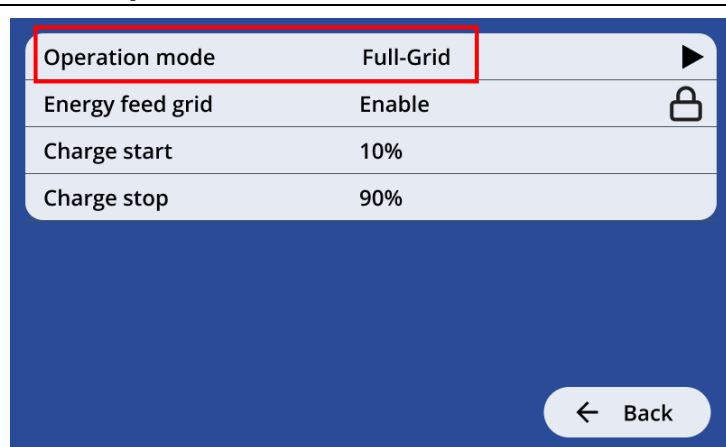

Full-Grid operation mode
 Applicable scenario: Ideal for regions with high electricity costs, this system gives priority to backup loads. When solar power generation surpasses the backup load requirements, the surplus energy is sent to the grid, limited by the inverter's maximum capacity. If solar generation falls short of meeting the backup loads completely, these loads remain prioritized, and any available solar power is still directed to the grid up to the inverter's maximum capacity.

Operation mode	Full-Grid	▶
Energy feed grid	Enable	🔒
Charge start	10%	
Charge stop	90%	

← Back

Energy feed grid:

If it is set to enabled, solar energy is allowed to feed into the grid, solar energy is not allowed to feed into the grid

Charge start:

The setting range is 5%~95% when the battery is connected to the BMS, and 44.0V~51.0V when no battery is connected to the BMS.

Charge stop:

The setting range is 10%~100% when the battery is connected to the BMS, and 48.0V~58.0V when no battery is connected to the BMS.

Schematic Diagram - full Grid

In Full Grid mode, backup loads are supplied with power from solar energy. Any surplus solar energy is sent back to the grid.

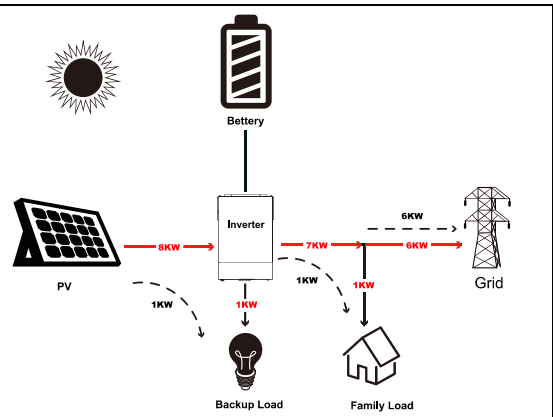

User operation mode

Operation mode	User	▶
Energy feed grid	<input checked="" type="checkbox"/>	
Solar supply priority	Battery-Load-Utility	▶
Charge source	Solar-and-Utility	▶
Output source	Solar-Utility-Battery	▶
Charge start	10%	
Charge stop	90%	

← Back

User operation mode

Energy feed grid:

A simple on/off switch to allow or prevent excess solar energy from being fed into the electrical grid.

Solar supply priority: This setting determines the order in which solar energy is used:

- Battery-Load-Utility: Battery charging is prioritized, then loads, and finally any excess goes to the utility grid.
- Load-Battery-Utility: Loads are prioritized, then battery charging, and finally, excess is sent to the grid.

Charge source :

- Solar-first: Solar energy will be used to charge the battery as the primary source. The utility will charge the

Operation mode User ▶

Note : time 0:00 means always enabled

Charging period	6:00 ▾	---	12:00 ▾
First discharge period	6:00 ▾	---	12:00 ▾

◀ ◀ Back

battery only when solar energy is unavailable.

- Solar-and-Utility: Solar energy and the utility grid will charge the battery simultaneously.
- Only solar: Solar energy will be the only charger source, no matter utility is available or not.

Output source :

- Solar-Utility-Battery: Solar energy provides power to the loads as a priority. If solar energy is not sufficient to power all connected loads, Utility energy will supply power to the loads at the same time.
- Solar -Battery-Utility: Solar energy provides power to the loads as a priority. If solar energy is not sufficient to power all connected loads, battery energy will supply power to the loads at the same time. The utility provides power to the loads only when the battery voltage drops to either the low-level warning voltage or the setting point "charge start", or when the solar and battery are not sufficient.

Charge start and Charge stop:

Suitable for Solar-Battery-Utility mode:
 When the battery voltage or state of charge (SOC) falls below the "Charge start" threshold, the battery begins charging. Once the battery voltage or SOC exceeds the "Charge stop" threshold, charging stops, and the battery starts discharging.

About

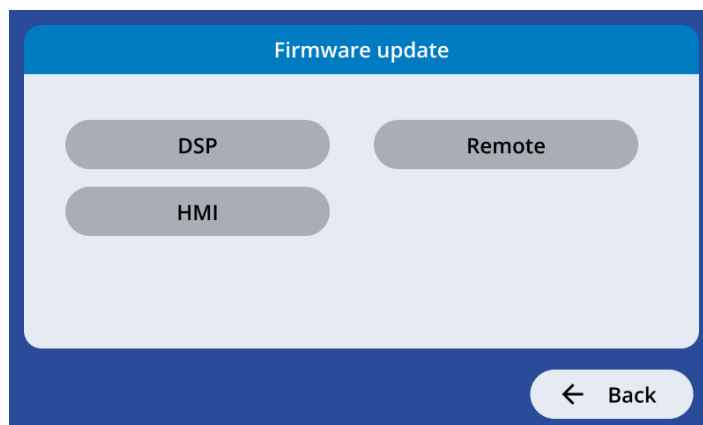
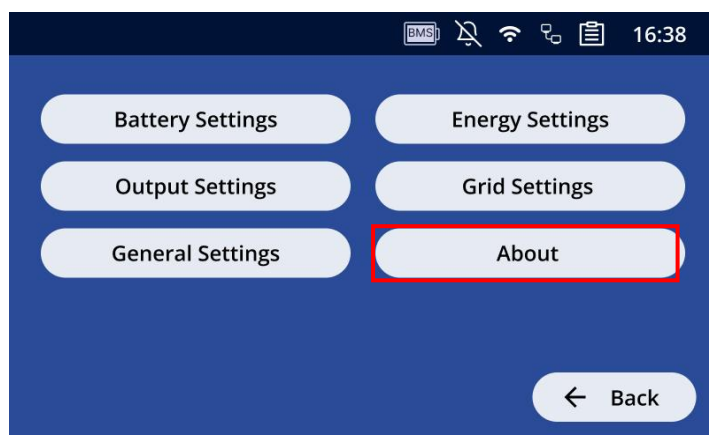

Model: brand and model

SN: serial number

DSP version: version number of DSP

Remote version: version number of Remote

MCU version: version number of MCU

LCD version: version number of LCD

Check update: check whether there is to-be-updated content

Check update:

Connect the USB flash drive with the upgrade file, click on Check Update →, and select the program DSP, Remote or HMI subject to update.

Please note: The USB flash drive should be formatted as FAT32. The DSP upgrade file must be named dsp.hex, the Remote upgrade file should be named mcu.hex, and the HMI upgrade file should be named XRD_TFT. All file names must be in lowercase, and all files need to be located in the root directory of the USB flash drive.

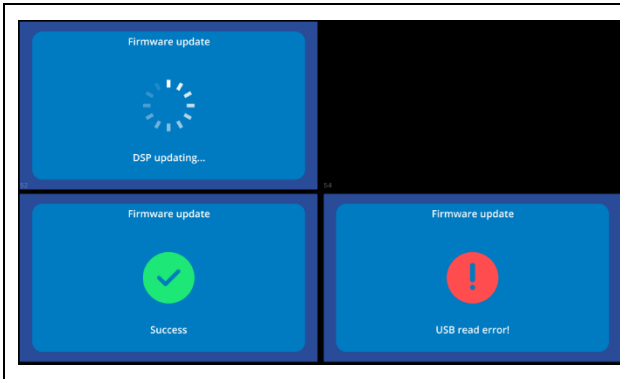

Upgrade details will be shown while the upgrade is in progress, and the screen will be unresponsive during this time. Once the upgrade is finished, the results will be displayed, and you can go back to the home page by clicking the screen icon.

Record and warning/fault code display

Tap the record or warning icon located in the top menu bar. Next, select "Export logs" to save the logs onto a connected USB flash drive. The USB drive should be formatted as FAT32 and use an MBR partition.

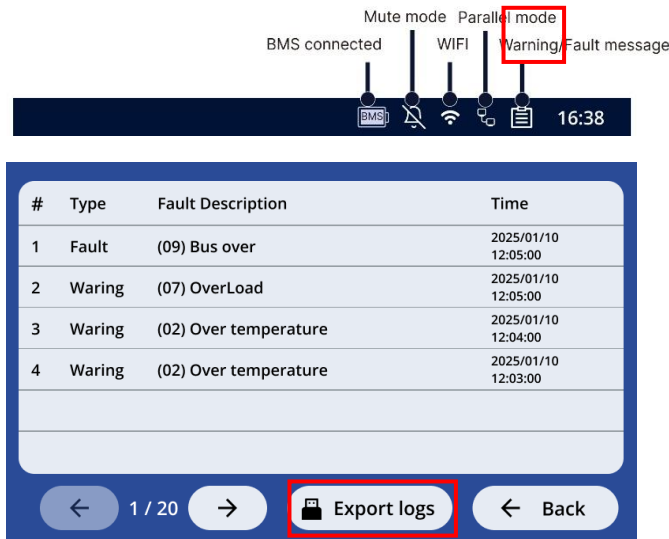

Faults/Warnings Reference Code

Fault Code	Event Description
2	Over Temperature
3	Battery VOL high
5	Output short circuited
6	AC-out VOL too high
7	Overload
8	BUS VOL exceed upper limit
9	BUS soft start timeout
10	PV over-current
11	PV overvoltage
12	DCDC over-current
51	INV over-current
52	BUS voltage too low
53	INV Soft Fail
55	INV output over-voltage
57	CUR sensor failed
58	AC-out VOL too low
60	Negative power flow detected
71	Parallel FW incompatible
72	Output sharing fault
80	CAN lost
81	HOST lost
82	SYN lost
83	Battery VOL different
84	VOL/FREQ different
85	AC input CUR unbalanced
86	Output setting different
99	MCU not normal

Warning Code	Event Description
1	Fan Lock
2	Over temperature
4	Battery low
7	Overload
10	Output derating
12	Battery open
61	BMS communication loss
60	BAT stop charge/discharge
62	BMS pack abnormal
69	Battery stop charging
70	Battery force charging
71	Battery stop discharging

CLEARANCE AND MAINTENANCE FOR ANTI-DUST KIT

Overview

Each inverter comes pre-installed with an anti-dusk kit from the factory. This kit protects the inverter from dusk conditions and enhances the product's reliability in harsh environments.

Clearance and Maintenance

Step 1: Unscrew the screws located on the side of the inverter as illustrated in the diagram below.

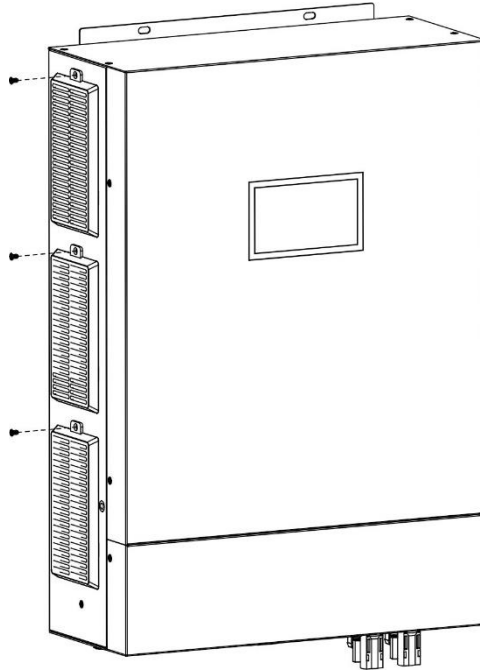

Step 2: Next, the dustproof case can be removed, and the air filter foam can be taken out as illustrated in the diagram below.

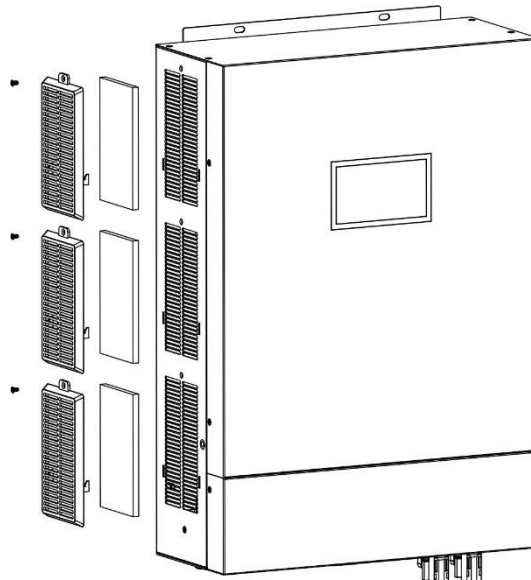

Step 3: Clean the air filter foam and dustproof case. After cleaning, reassemble the dust kit onto the inverter.
NOTICE: The anti-dust kit should be cleaned of dust every month.

SPECIFICATIONS

MODEL	6.2KW
RATED OUTPUT POWER	8200W with PV & battery, 6200W with battery only
PV INPUT (DC)	
Max. PV Power	9000W (PV1 + PV2: 4500W + 4500W) (PV1 or PV2: 7000W)
Max. PV Array Open Circuit Voltage	500 VDC
PV Input Voltage Range	120 VDC~500 VDC
MPPT Range @ Operating Voltage	85 VDC~430 VDC
Max. PV Array Short Circuit Current	22A + 22A
Number of MPP Tracker	2
GRID-TIE OPERATION	
GRID OUTPUT (AC)	
Nominal Output Voltage	220/230/240 VAC
Feed-in Grid Voltage Range	195.5~253 VAC @ Pakistan regulation 184 ~ 264.5 VAC @Germany regulation 184 ~ 264.5 VAC @South America regulation
Feed-in Grid Frequency Range	49~51Hz @ Pakistan regulation 47.5~51.5Hz @Germany regulation 57~62Hz @South America regulation
Nominal Output Current	35.66A
Rated Feed-in Grid Power	8200W
Power Factor Range	>0.99
Maximum Conversion Efficiency (DC/AC)	96%
OFF-GRID, HYBRID OPERATION	
GRID INPUT	
Acceptable Input Voltage Range	90 - 280 VAC or 170 - 280 VAC
Frequency Range	50 Hz/60 Hz (Auto sensing)
Transfer Time	< 10ms (For UPS) < 20ms (For Home Appliances) < 50ms (For parallel operation)
Rating of AC Transfer Relay	40A
BATTERY MODE OUTPUT (AC)	
Nominal Output Voltage	220/230/240 VAC
Rated Power	6200W
Output Waveform	Pure Sine Wave
Nominal Output Current	27A
Efficiency (DC to AC)	93%
BATTERY & CHARGER	
Nominal DC Voltage	48 VDC
Maximum Charging Current (from Grid)	120A
Maximum Charging Current (from PV)	130A
Maximum Charging Current	130A
GENERAL	
Dimension, D X W X H (mm)	138.4 x 338 x 491.8
Net Weight (kgs)	12
INTERFACE	
Parallel-able	Yes, 9 units
External Safety Box (Optional)	Yes
Communication	RS232/Dry-Contact/Wi-Fi
ENVIRONMENT	
Humidity	0 ~ 90% RH (No condensing)
Operating Temperature	-10°C to 50°C

TROUBLE SHOOTING

Problem	LCD/ Buzzer	Explanation / Possible cause	What to do
The unit powers off on its own during the startup sequence.	The HMI and buzzer will be activated for 3 seconds and then turn off completely.	The battery voltage is insufficient (below 1.91V per cell).	1. Recharge the battery. 2. Install a new battery.
No reaction after turning on the power.	No indication.	1. The battery voltage is significantly low (less than 1.4 volts per cell). 2. The battery is connected with reversed polarity.	1. Verify that the batteries and wiring are properly connected. 2. Recharge the battery. 3. Replace the battery.
The mains power is available, but the unit is operating on battery power.	The HMI indicates that the grid voltage is 0V.	The input protector is tripped	Verify whether the AC breaker has tripped and ensure that the AC wiring is properly connected.
	Grid does not exist.	Poor quality of AC power (from shore supply or generator).	1. Verify whether the AC wires are excessively thin or too lengthy. 2. Confirm that the generator (if used) is functioning properly and that the input voltage range setting is accurate. (UPS to Appliance)
When the unit is powered on, the internal relay continuously switches on and off.	Battery compartment open	The battery has been disconnected.	Verify that the battery wires are properly connected.
The buzzer is sounding continuously, and the red LED remains lit.	Over-load	Overload error. The inverter is overloaded by 110%, and the time limit has been reached.	Reduce the connected load by switching off some equipment.
	Output short circuited	Output short-circuited.	Check if the wiring is connected well and remove the abnormal load.
	Over Temperature	Operating temperature inside the inverter component	Check whether the air flow of the unit is blocked or whether the ambient temperature is too high.
	Battery VOL high	The battery is overcharged.	Return to the repair center.
		The battery voltage is too high.	Check if the spec and quantity of batteries meet requirements.
	Fan locked	Fan warning.	Replace the fan.
	AC-out VOL too low. / AC-out VOL too high	Output abnormal (Inverter voltage below 190Vac or is higher than 260Vac)	1. Reduce the connected load. 2. Return to the repair center
	BUS soft start timeout / BUS voltage exceeds upper limit / Inverter soft failure / Current sensor malfunction	Internal components failed.	Return to the repair center.
	PV overcurrent	PV current is too high	Please restart the device. If the error occurs again, kindly take it to the repair center.
	DCDC overcurrent	DC/DC overcurrent or surge.	
	INV overcurrent	Over current or surge.	
	BUS voltage too low.	Bus voltage is too low.	
Output sharing fault	Output voltage is unbalanced.		
PV overvoltage	Solar input voltage is more than 500V.		

Appendix I: Parallel function

1. Introduction

This inverter can operate in parallel using two different modes:

1. Single-phase parallel operation supports up to 9 units, with a maximum output power of 54KW/54KVA.
2. Up to 9 units can work together to support three-phase equipment, with a maximum of seven units per phase.

NOTE: If the unit comes with a shared current cable and parallel cable, parallel operation is supported by default, and you can skip section 3. Otherwise, please purchase a parallel kit and have the installation performed by qualified technical personnel at your local dealer.

WARNING: Ensure that all output neutral (N) wires from each inverter are always connected; failure to do so may cause errors or faults.

2. Package Contents

In the parallel kit, you will find the following items in the package:

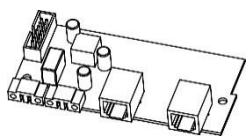

Parallel board



Parallel communication cable



Current sharing cable

3. Parallel board installation

Step 1: Remove the wire cover by unscrewing all screws.

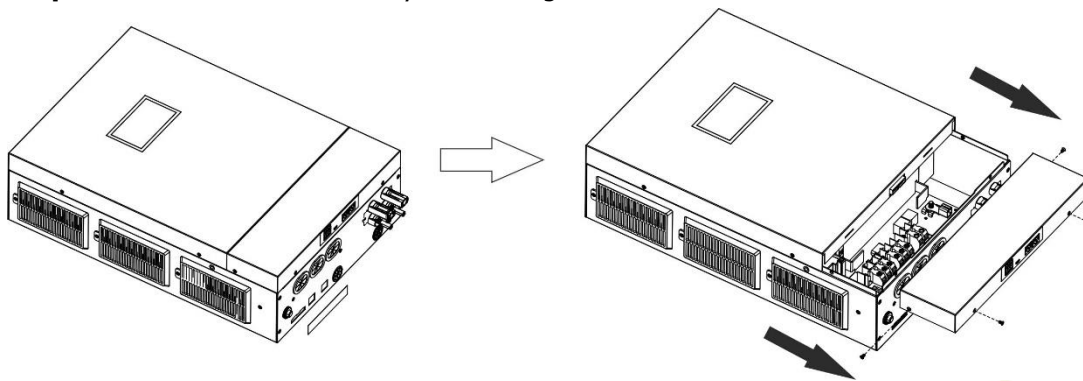

Step 2: Remove three screws as below chart and remove the terminal block.

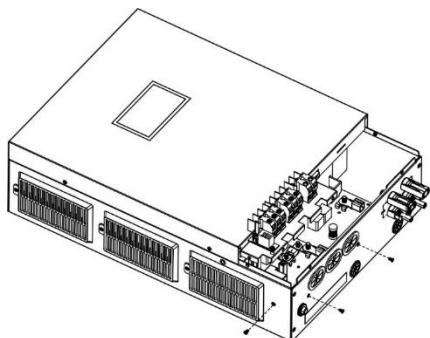

Step 3: Press the spot pointed to by the arrow to disconnect and take out the 2-pin cable highlighted by the red square.

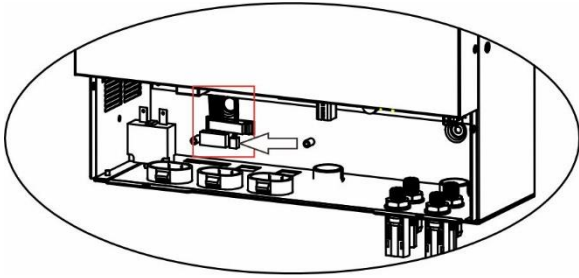

Step 4: Install the new parallel board with two screws tightly.

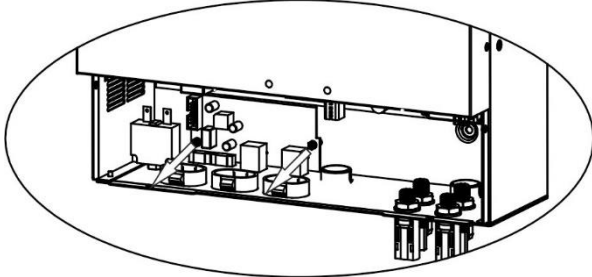

Step 5: Re-connect the 2-pin to the original position.

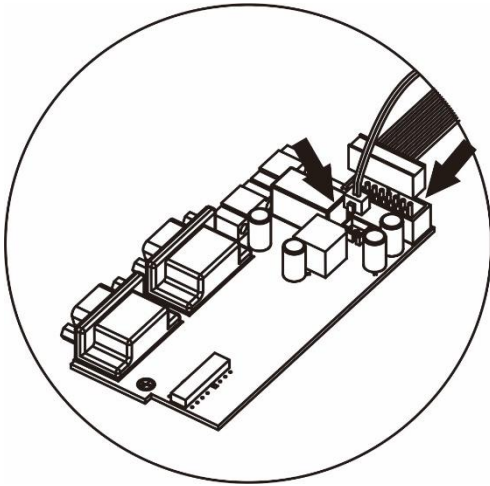

Step 6: Put the wire cover back on the unit. Now the inverter is providing a parallel operation function.

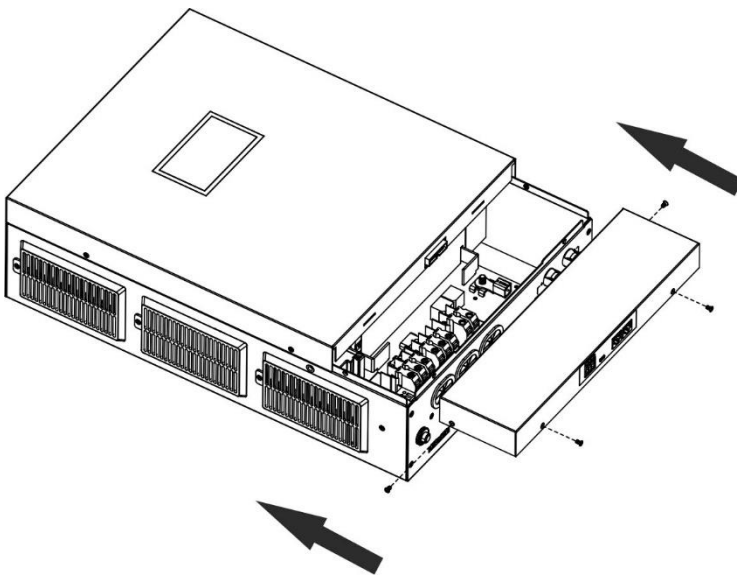

4. Mounting the Unit

When installing multiple units, please follow the chart below.

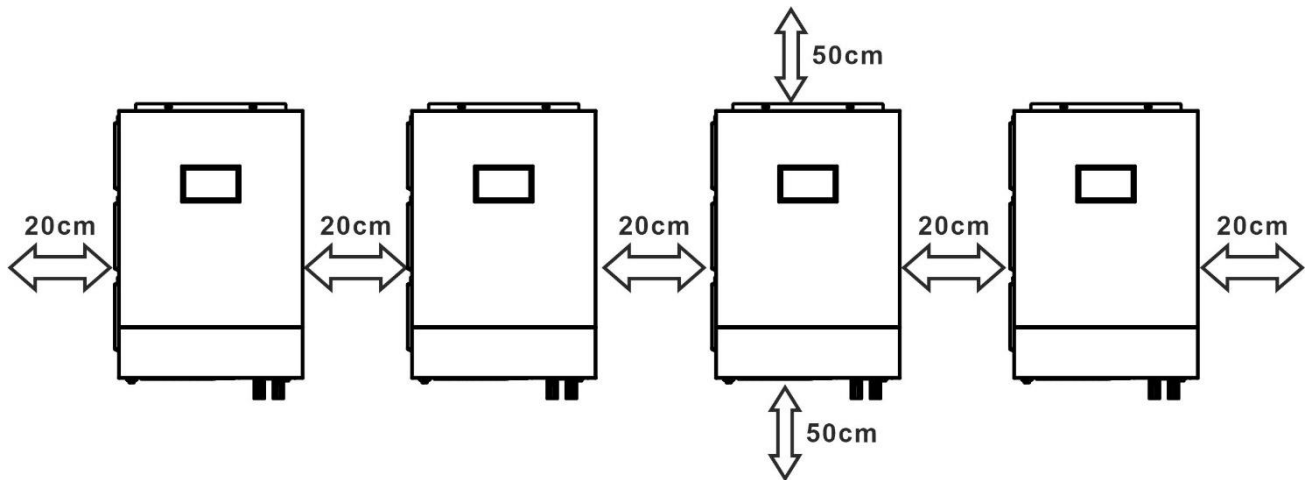

NOTE: For proper air circulation to dissipate heat, allow a clearance of approx 20 cm to the side and approx. 50 cm above and below the unit. Be sure to install each unit on the same level.

5. Wiring Connection

NOTICE: It's requested to connect to the battery for parallel operation.

The cable size of each inverter is shown below:

Recommended battery cable and terminal size for each inverter:

Model	Wire Size	Ring Terminal			Torque value
		Cable mm ²	Dimensions		
			D (mm)	L (mm)	
6.2KW	1*2AWG or 2*6AWG	28	6.4	42.7	2~3 Nm

Ring terminal:

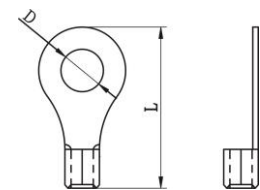

WARNING: Ensure that all battery cables are of equal length. If not, voltage differences between the inverter and battery may occur, causing parallel inverters to malfunction.

Recommended AC input and output cable size for each inverter:

Model	AWG no.	Torque
6.2KW	8 AWG	1.4~1.6Nm

You need to link the cables of each inverter together. For instance, with the battery cables, use a connector or bus-bar to join the battery cables, then connect this joint to the battery terminal. The cable size from the joint to the battery should be X times the cable size specified in the tables above, where "X" represents the number of inverters connected in parallel. The same approach should be applied to the AC input and output cables.

WARNING!! Ensure that all output N wires of each inverter remain connected at all times. Failure to do so will result in an inverter fault error.

CAUTION!! Please install a breaker on both the battery side and the AC input side. This will allow the inverter to be safely disconnected during maintenance and provide full protection against overcurrent from the battery or AC input. The suggested mounting locations for the breakers are illustrated in the diagrams in sections 5-1 and 5-2.

Recommended breaker specification of battery for each inverter:

Model	1 unit*
6.2KW	170A/70VDC

*If you want to use only one breaker at the battery side for the whole system, the rating of the breaker should be X times the current of 1 unit. "X" indicates the number of inverters connected in parallel.

Recommended breaker specification of AC input with single phase:

Model	2 units	3 units	4 units	5 units	6 units	7 units	8 units	9 units
6.2KW	80A/ 230VAC	120A/ 230VAC	160A/ 230VAC	200A/ 230VAC	240A/ 230VAC	280A/ 230VAC	320A/ 230VAC	360A/ 230VAC

Note1: Use a 50A breaker for a single unit and install one breaker at the AC input of each inverter.

Note2: For a three-phase system, you can use a 4-pole breaker directly, and the breaker's rating should match the phase current limit of the phase with the highest number of units.

Recommended battery capacity

Inverter parallel numbers	2	3	4	5	6	7	8	9
Battery Capacity	400AH	600AH	800AH	1000AH	1200AH	1400AH	1600AH	1800AH

WARNING! Make sure that all inverters are connected to the same battery bank; otherwise, the inverters will switch to fault mode.

5-1. Parallel Operation in Single-Phase

Two units connected in parallel:

Power Connection

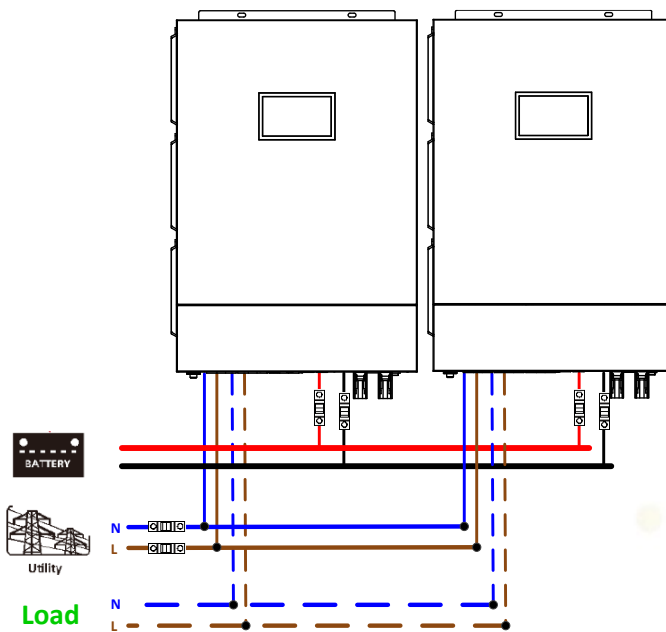

Communication Connection

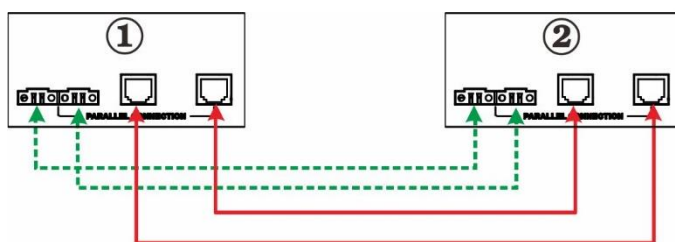

Three units connected in parallel:

Power Connection

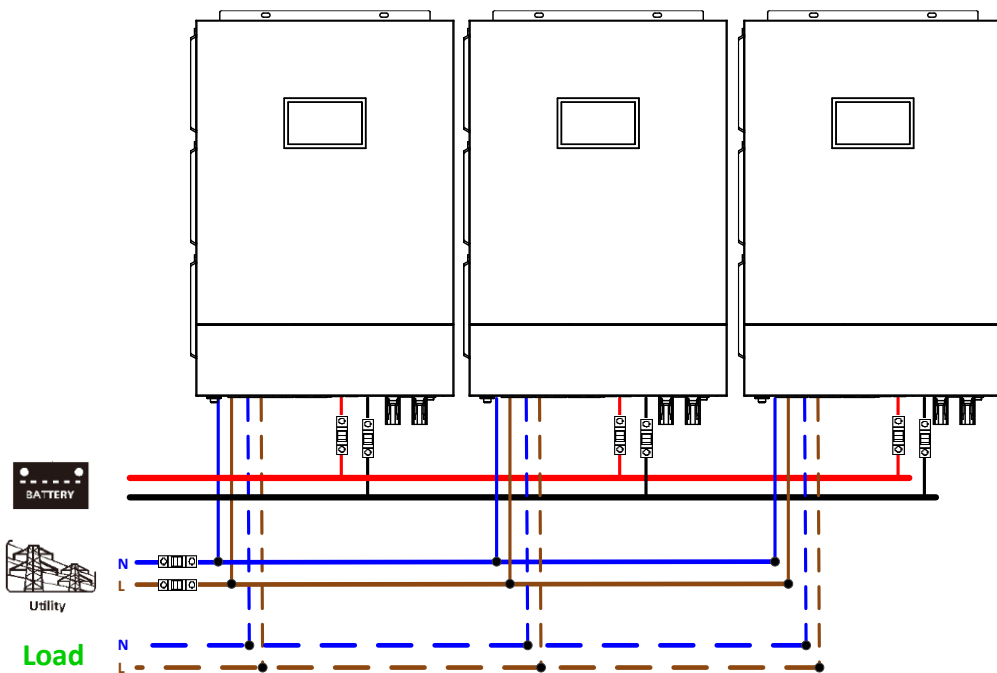

Communication Connection

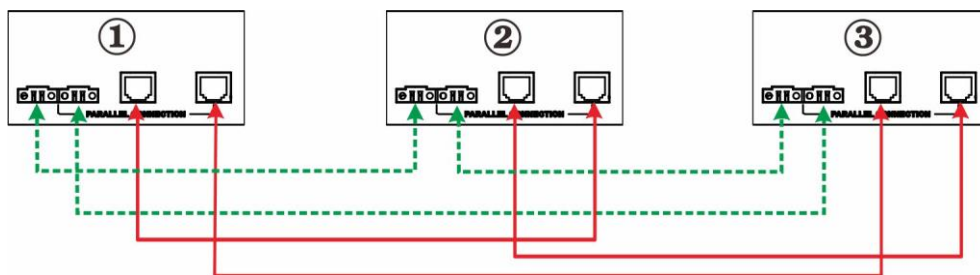

Four units connected in parallel:

Power Connection

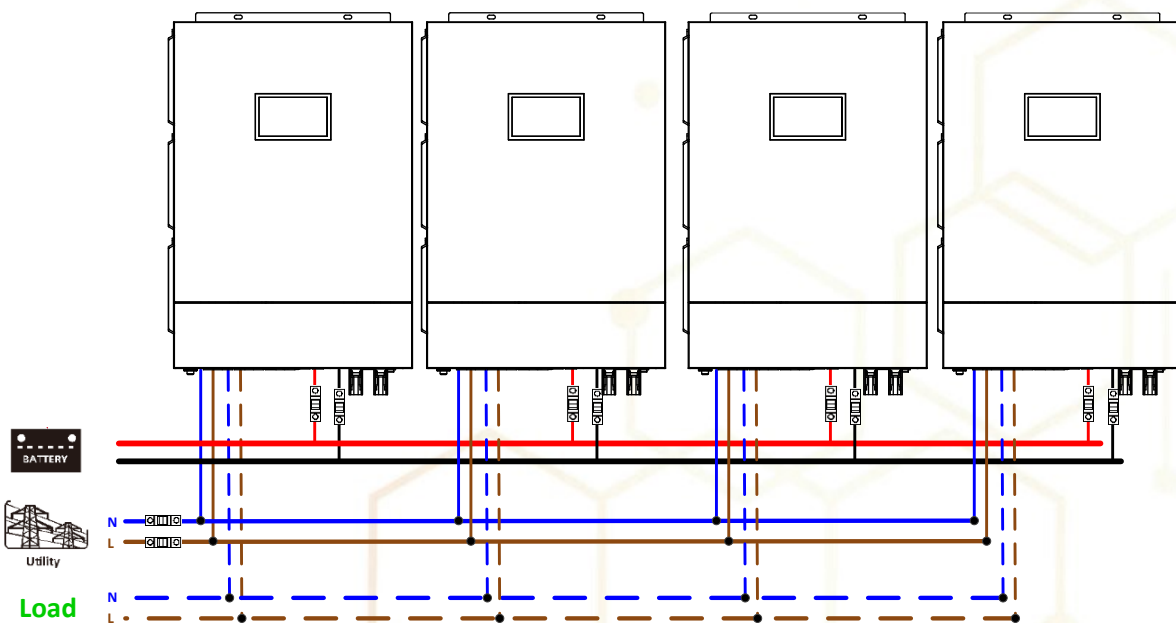

Communication Connection

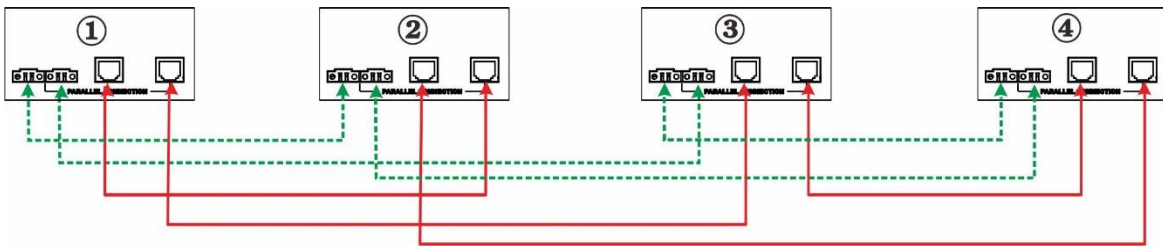

Five units connected in parallel:

Power Connection

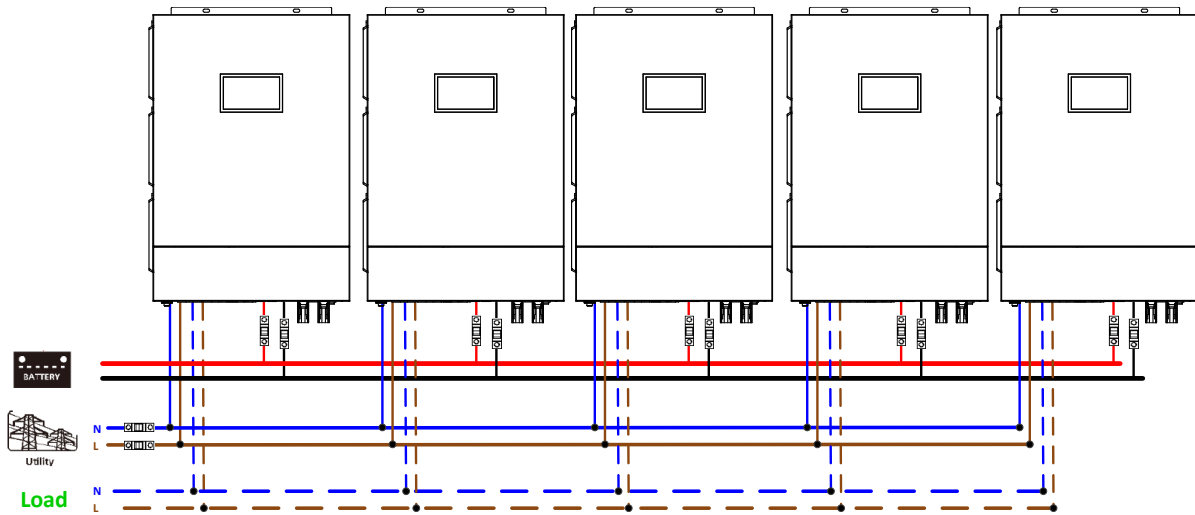

Communication Connection

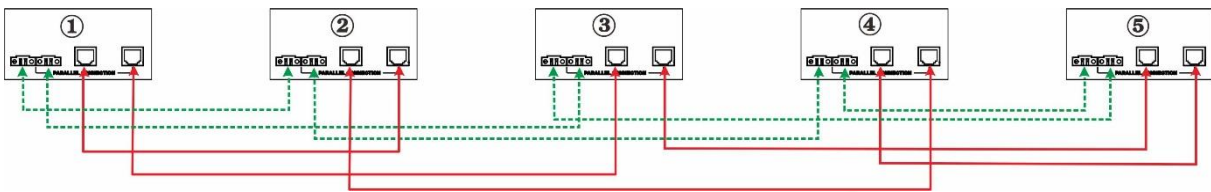

Six units connected in parallel:

Power Connection

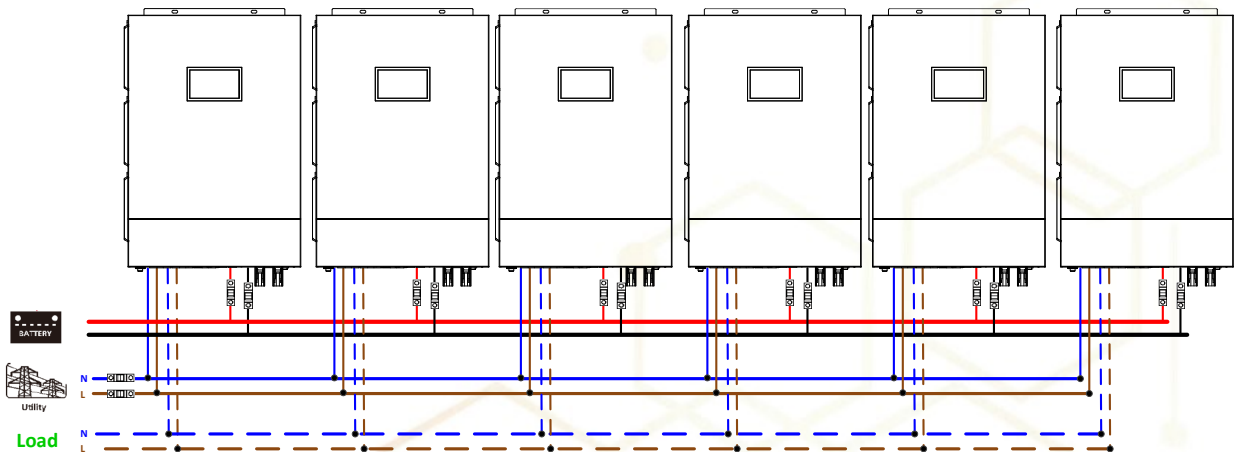

Communication Connection

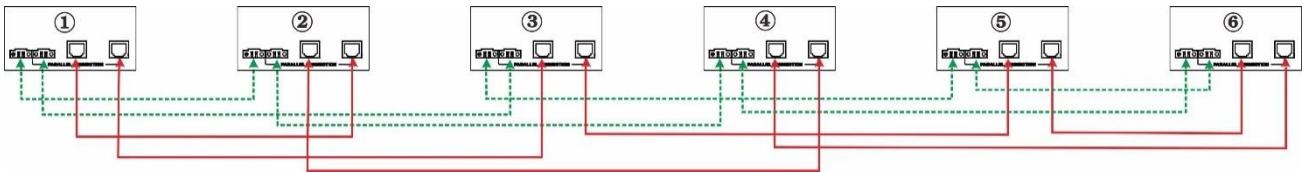

Seven units connected in parallel:

Power Connection

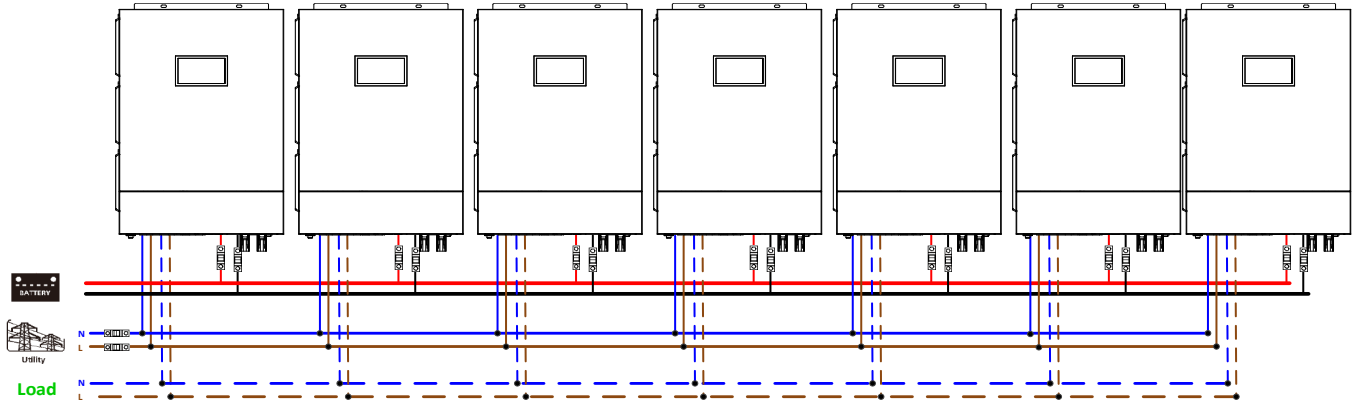

Communication Connection

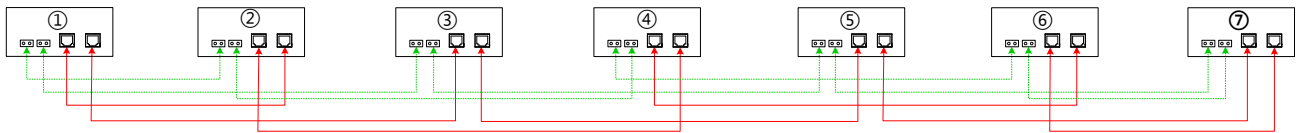

Eight units connected in parallel:

Power Connection

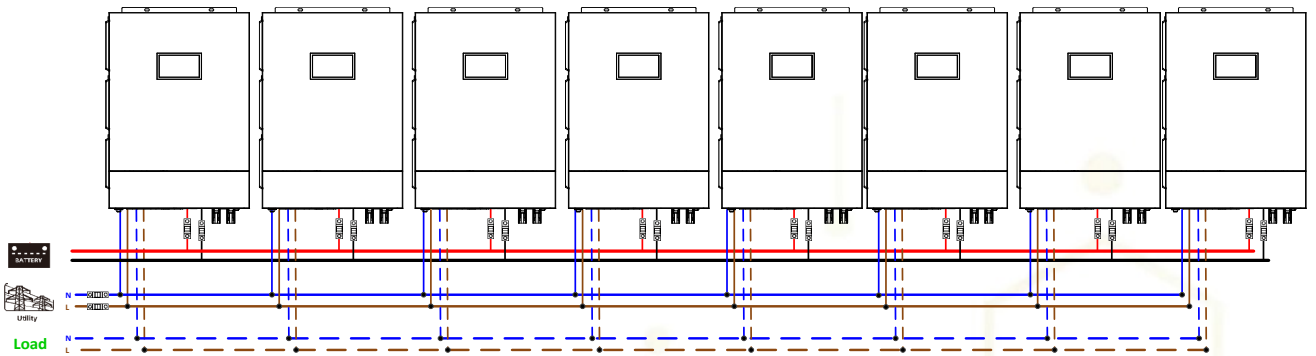

Communication Connection

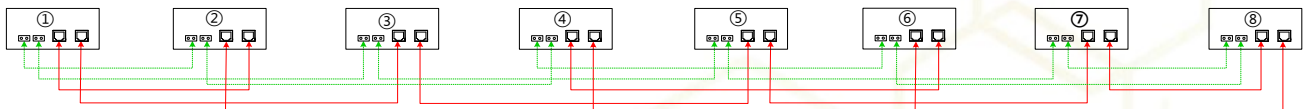

Nine units connected in parallel:

Power Connection

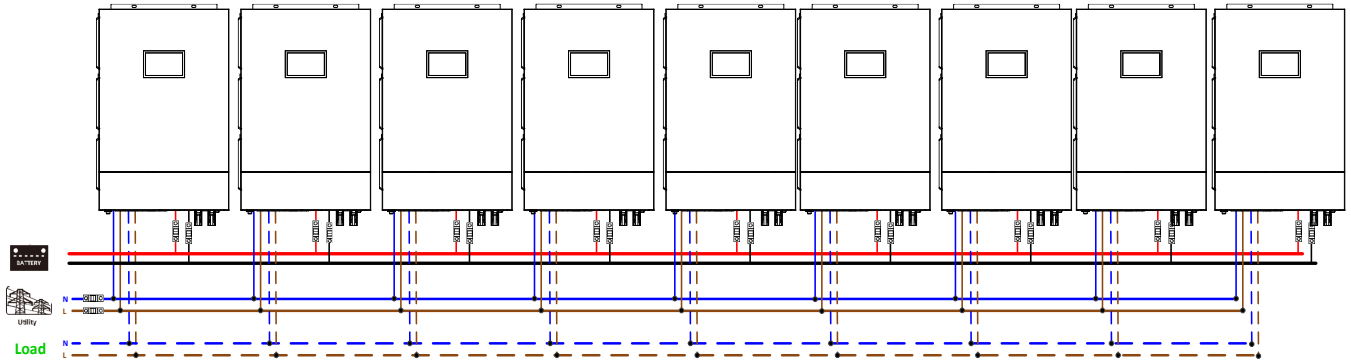

Communication Connection

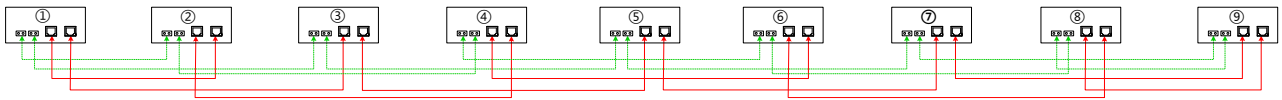

5-2. Support 3-phase equipment

Three inverters in each phase:

Power Connection

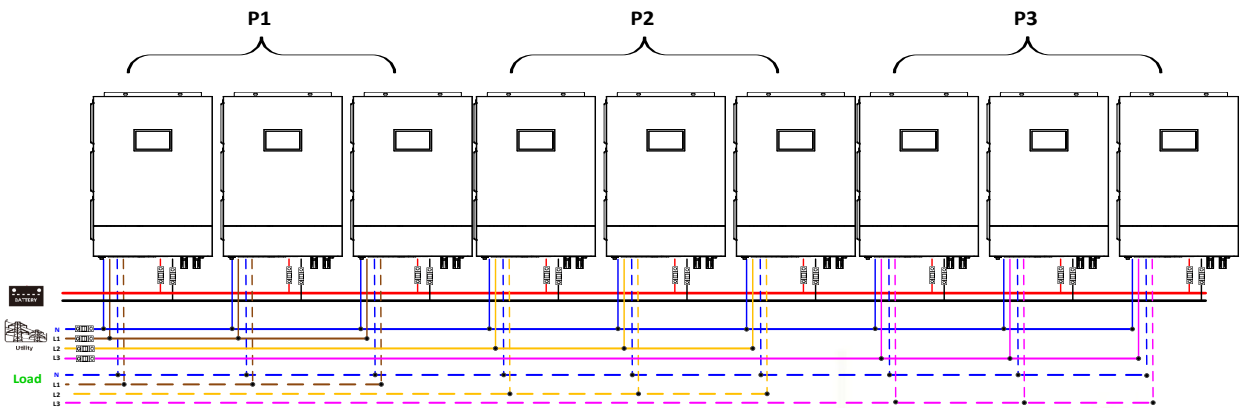

Communication Connection

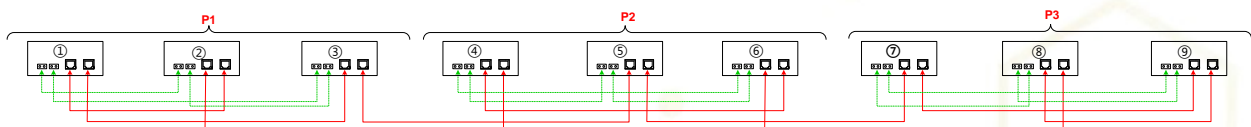

Three inverters in one phase, three inverters in second phase and two inverters for the third phase:

Power Connection

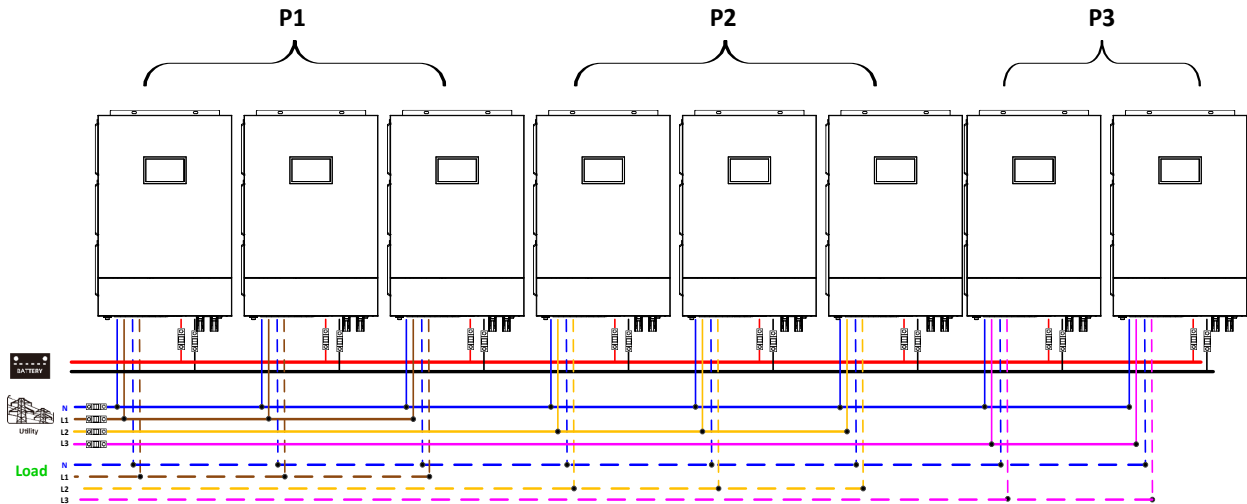

Communication Connection

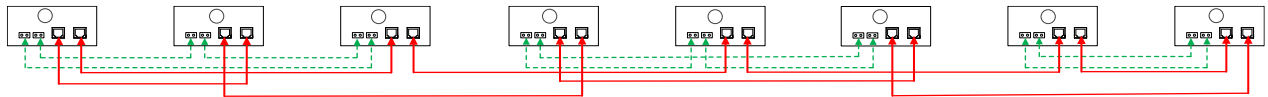

Seven inverters in one phase and one inverter for the other two phases:

Power Connection

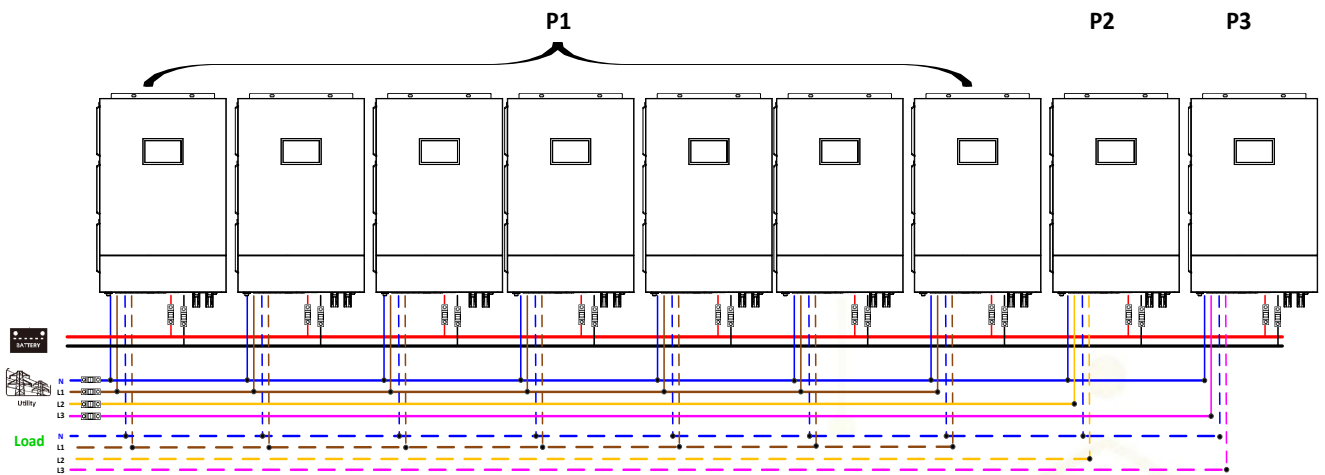

Note: It's up to customer's demand to pick 7 inverters on any phase.

P1: L1-phase, P2: L2-phase, P3: L3-phase.

Communication Connection

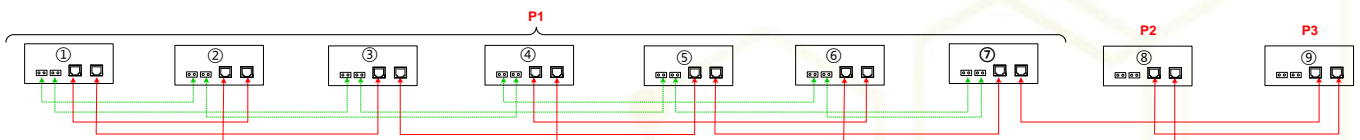

Note: If there is only one unit in one phase, this unit doesn't need to connect the current sharing cable.

Or you connect it like as below:

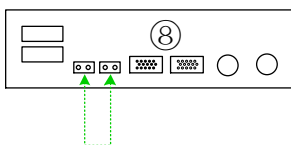

Three inverters in one phase, two inverters in the second phase, and two inverters for the third phase:

Power Connection

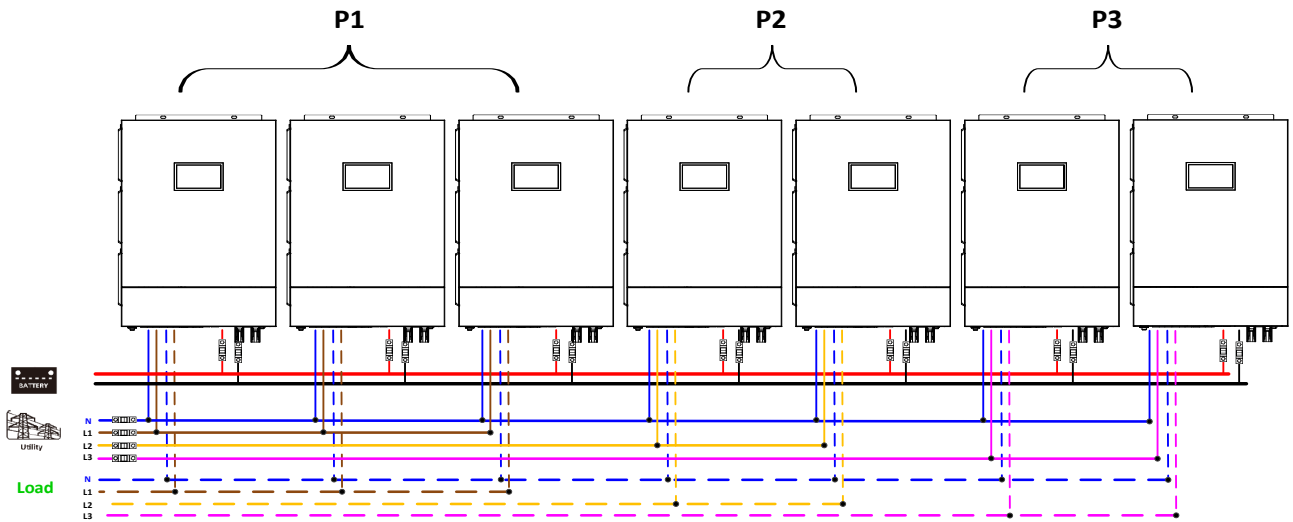

Communication Connection

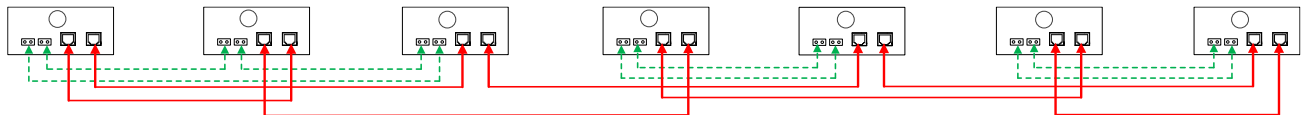

Two inverters in each phase:

Power Connection

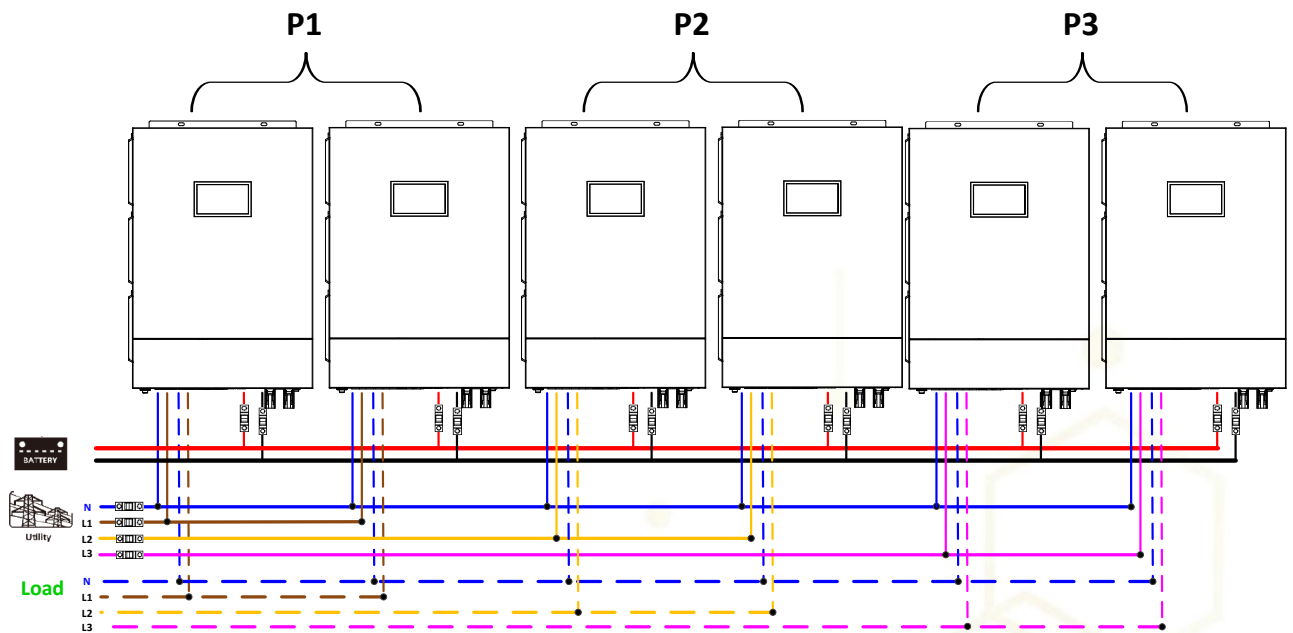

Communication Connection

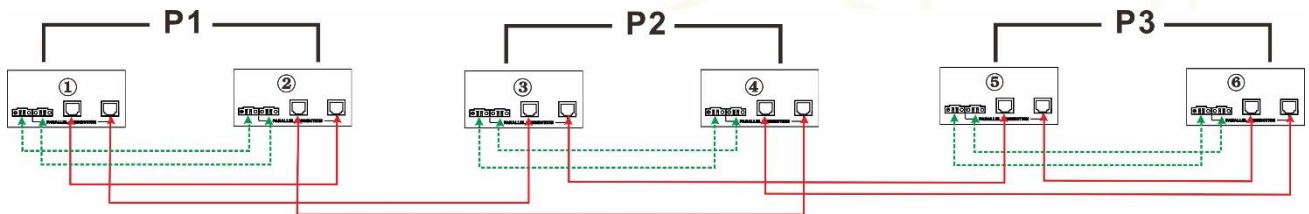

Four inverters in one phase and one inverter for the other two phases:

Power Connection

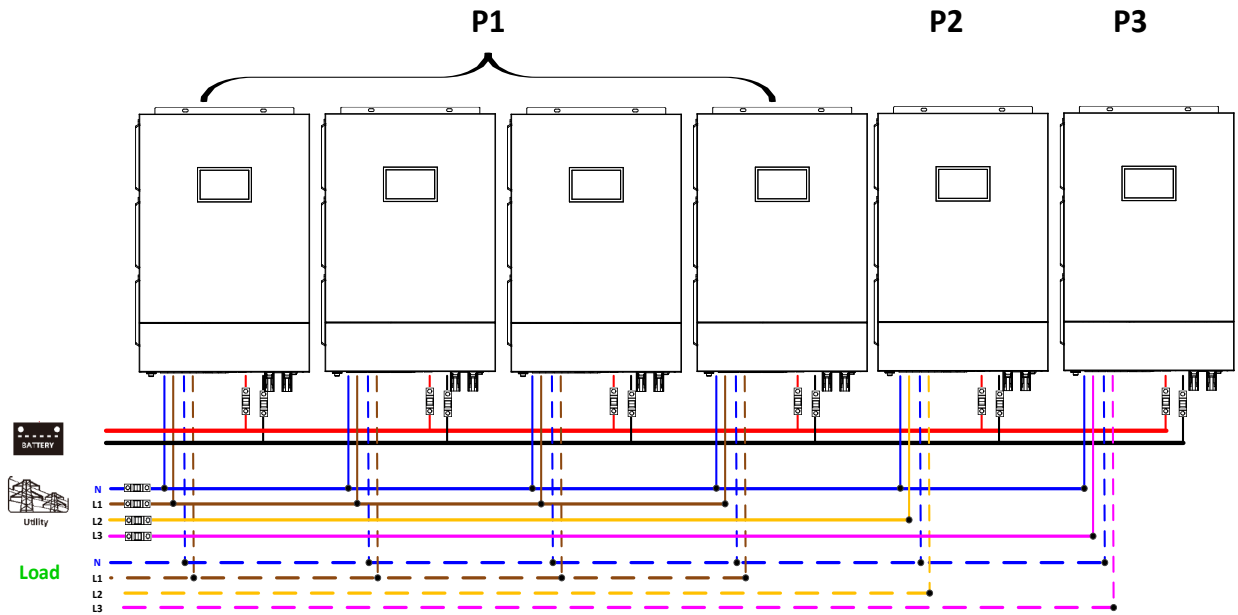

Communication Connection

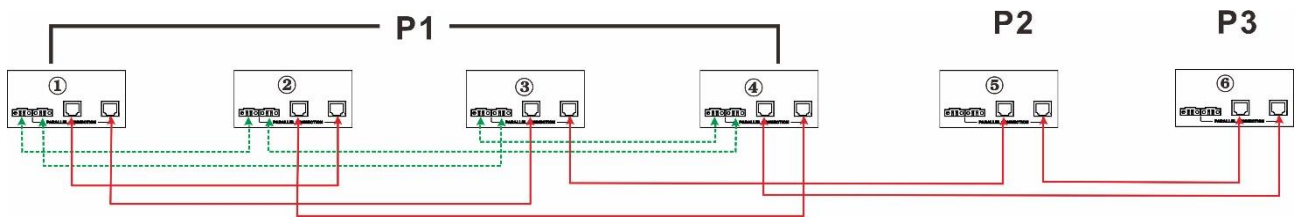

Three inverters in one phase, two inverters in second phase and one inverter for the third phase:

Power Connection

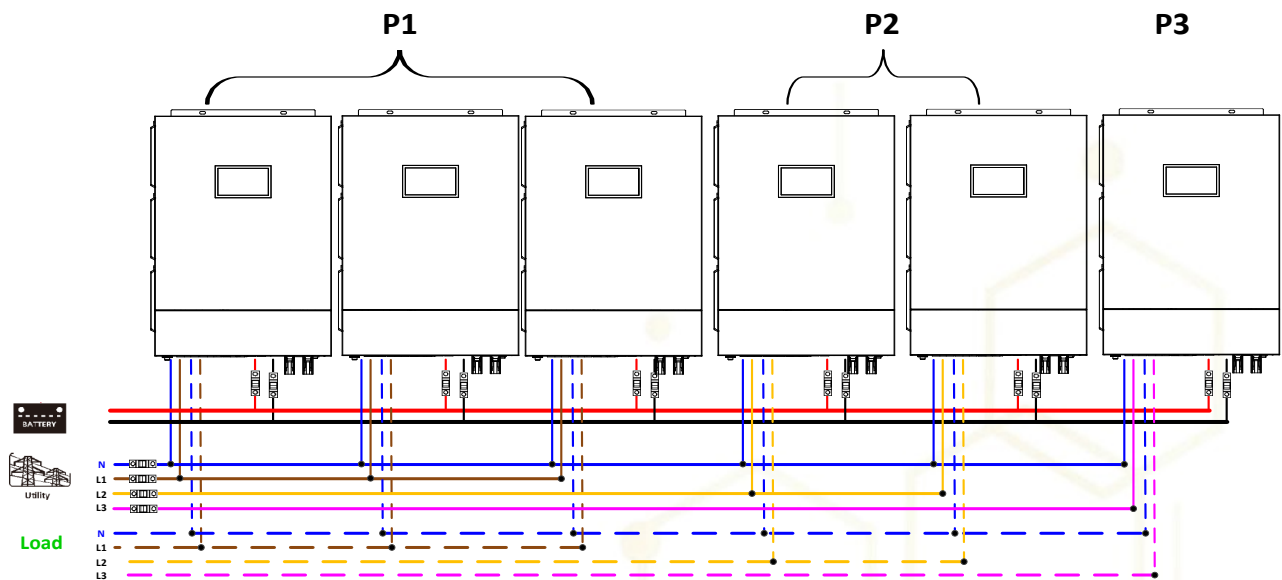

Communication Connection

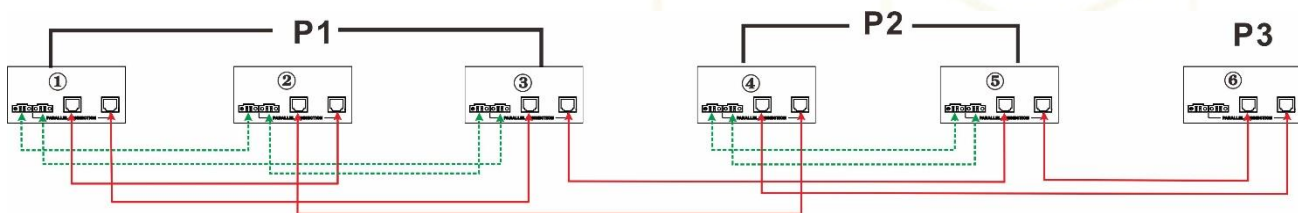

Three inverters in one phase and only one inverter for the remaining two phases:

Power Connection

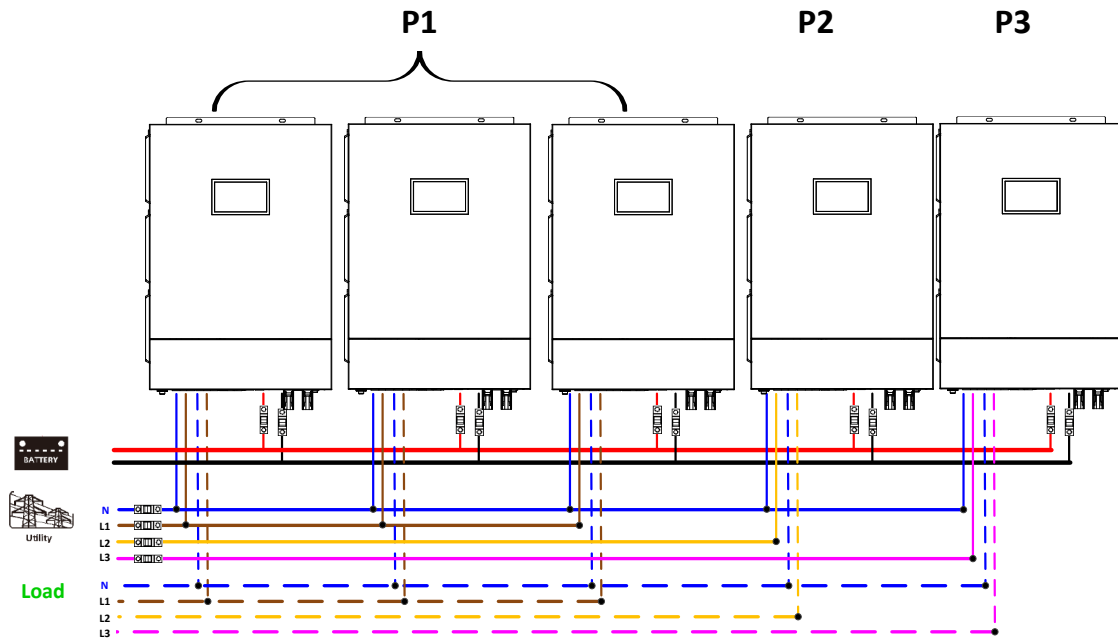

Communication Connection

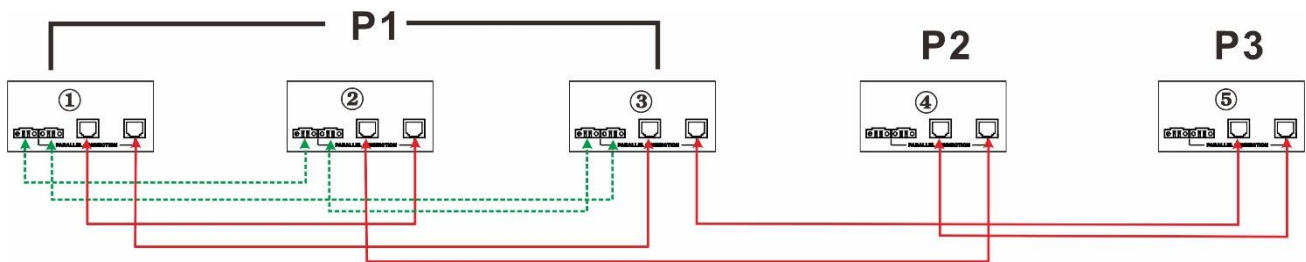

Two inverters in two phases and only one inverter for the remaining phase:

Power Connection

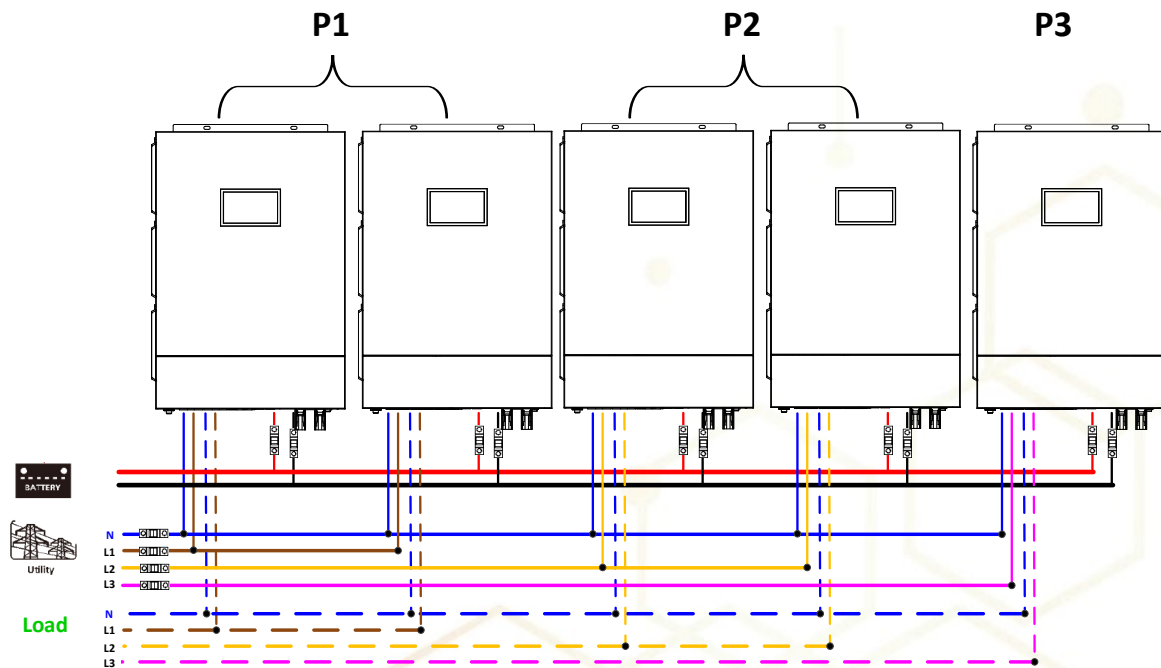

Communication Connection

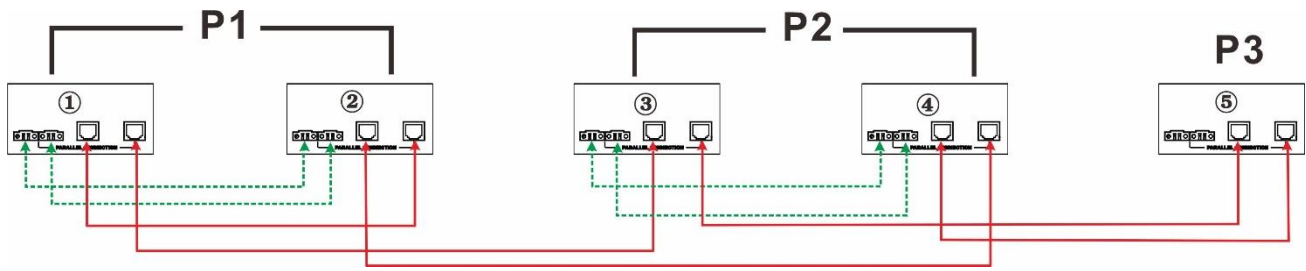

Two inverters in one phase and only one inverter for the remaining phases:

Power Connection

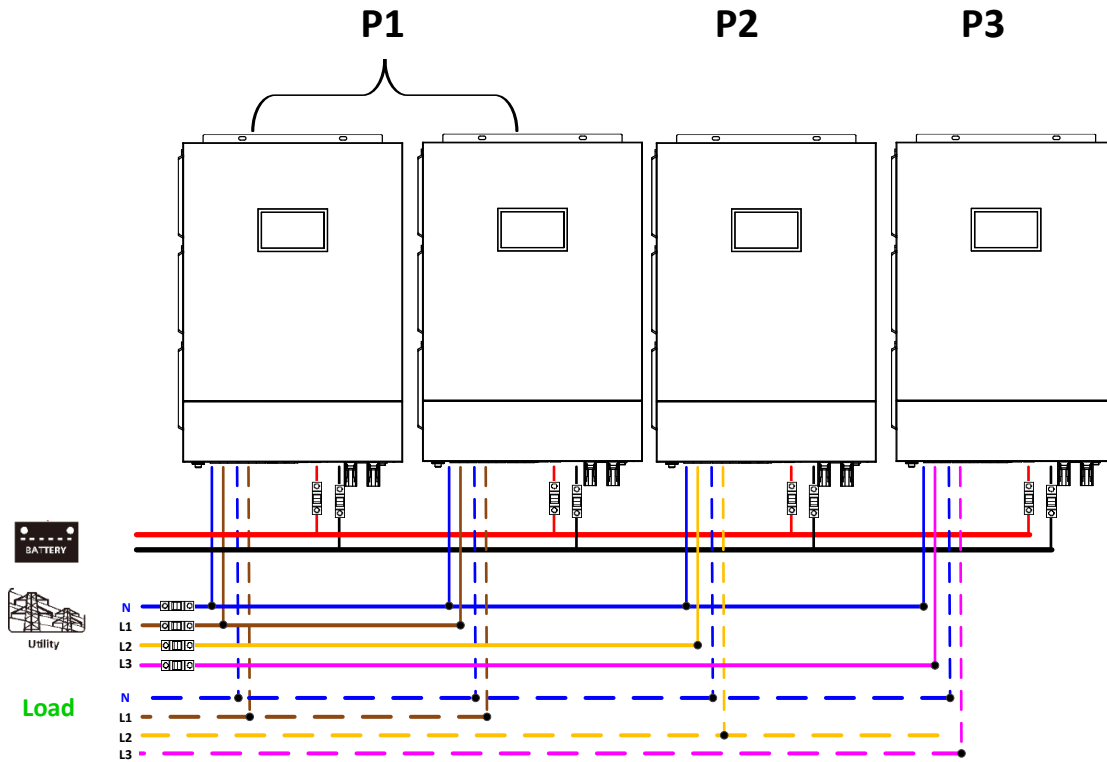

Communication Connection

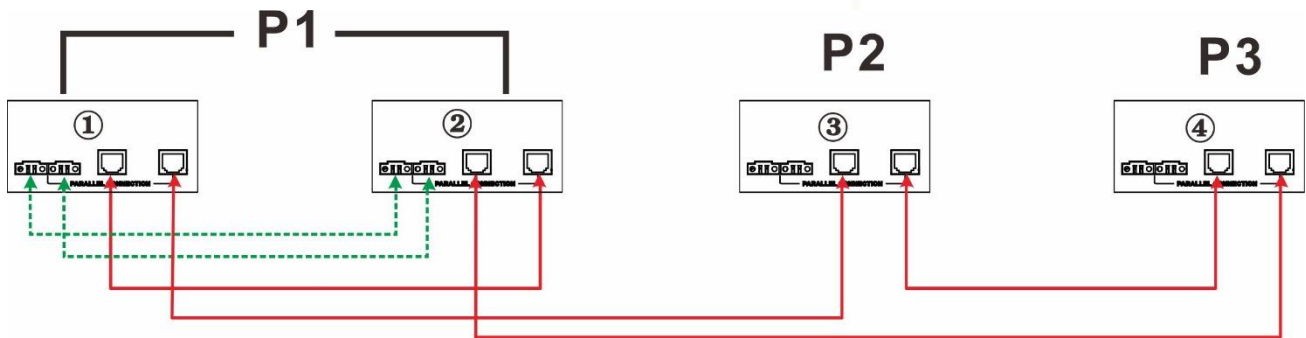

One inverter in each phase:

Power Connection

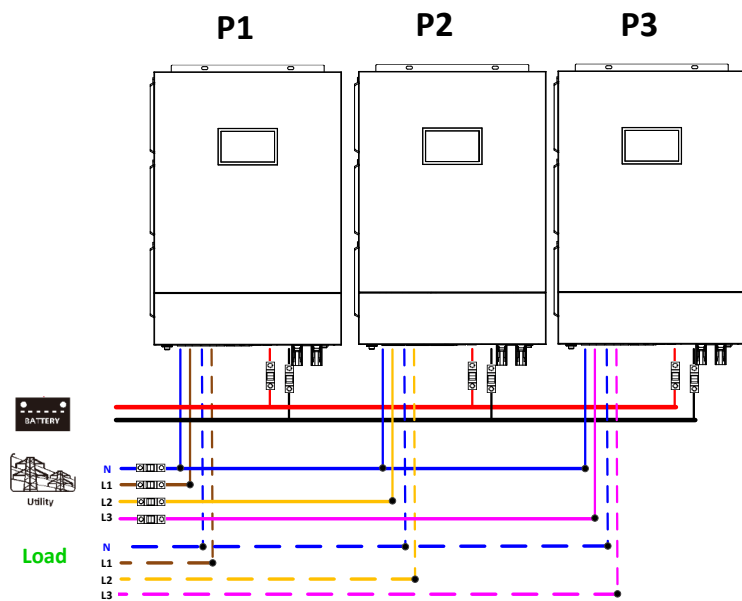

Communication Connection

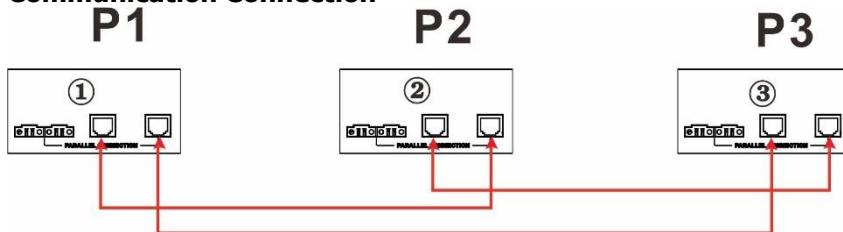

WARNING: Do not connect the current sharing cable between the inverters that are in different phases. Otherwise, it may damage the inverters.

6. PV Connection

Please consult the user manual of the individual unit for PV connection instructions.

CAUTION: Each inverter should connect to PV modules separately.

6. LCD Setting and Display

Parallel mode can be set according to the steps: Output setting→Output mode→ Parallel.

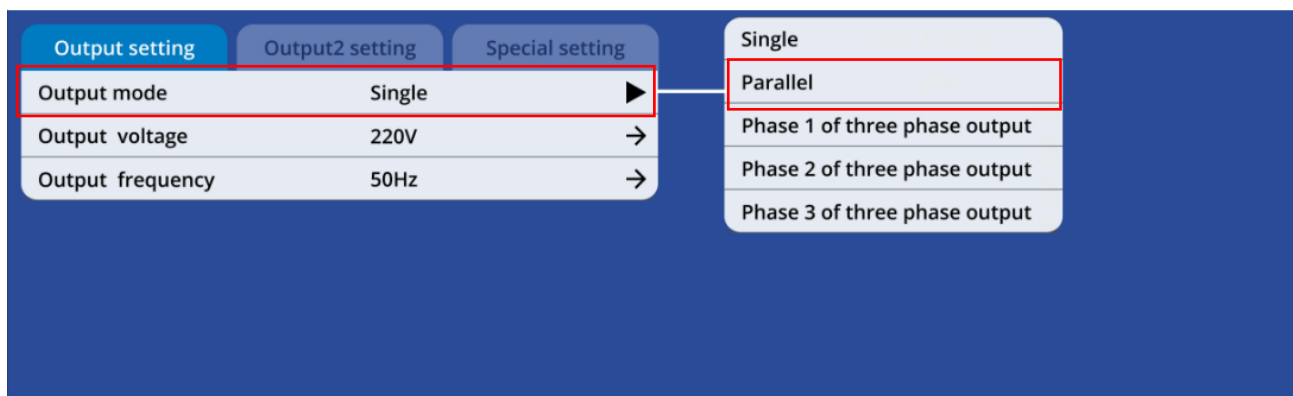
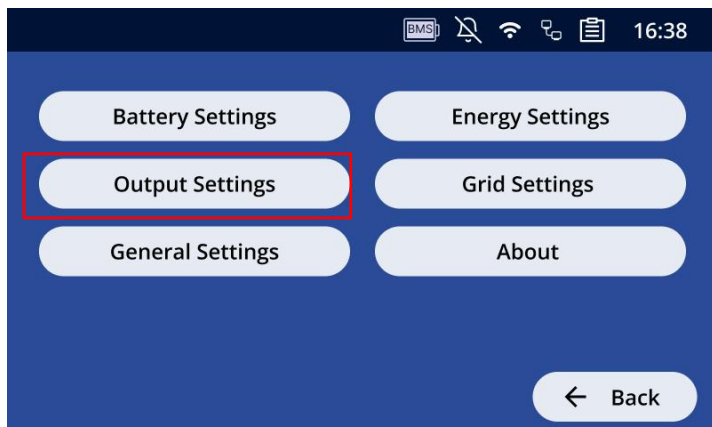

Program	Description	Selectable option
Output Setting	AC output mode *This setting is only available when the inverter is in standby mode (Switch off).	Single
		Parallel
		Phase 1
		Phase 2
		Phase 3
		When operating units in parallel with a single phase, please choose "Parallel" in the program's Output Setting under AC output mode.
		To support three-phase equipment, you need at least 3 inverters and no more than 9. Each phase must have at least one inverter, with a maximum of four inverters allowed per phase. For inverters connected to the L1 phase, select "Phase1" in the program's AC output mode; for those connected to L2, select "Phase2"; and for those connected to L3, select "Phase3."
		Make sure to connect the shared current cable only between units on the same phase. Do NOT connect the shared current cable between units on different phases.
		Additionally, the power-saving function will be automatically disabled.

Fault code display:

Fault Code	Fault Event
Negative power flow detected	Power feedback protection
FW Different	Firmware version inconsistent
Current sensor failure.	Current sharing fault
CAN lost	CAN fault
HOST lost	Host loss
SYN lost	Synchronization loss
Par-bat fault	Battery voltage is detected differently
VOL/FREQ different	The AC output current imbalance
Output setting different	The AC output mode setting is different

7. Troubleshooting

Situation		Solution
Fault Code	Fault Event Description	
Reverse power flow detected	The inverter is detecting feedback from the output.	<ol style="list-style-type: none"> Restart the inverter. Verify that the L/N cables are not reversed in any of the inverters. For a single-phase parallel system, ensure that the sharing cables are connected to all inverters. For a three-phase system, make sure the sharing cables are connected only between inverters on the same phase and disconnected between inverters on different phases. If the issue persists, please contact your installer.
Parallel FW incompatible	The firmware version of each inverter is not the same.	<ol style="list-style-type: none"> Ensure all inverter firmware is updated to the same version. Verify the version of each inverter through the LCD settings and confirm that the CPU versions match. If they do not, please reach out to your installer to obtain the necessary firmware for updating. If the issue persists after updating, please contact your installer for further assistance.
The CUR sensor failed	The output current of each inverter is different.	<ol style="list-style-type: none"> Check if the sharing cables are connected well and restart the inverter. If the problem remains, please contact your installer.
CAN lost	CAN data loss	<ol style="list-style-type: none"> Check if the communication cables are connected well and restart the inverter. If the problem remains, please contact your installer.
HOST lost	Host data loss	
SYN lost	Synchronization data loss	
Battery VOL different	The battery voltage of each inverter is not the same.	<ol style="list-style-type: none"> Ensure that all inverters are connected to the same groups of batteries. Disconnect all loads, as well as the AC and PV inputs. Then, measure the battery voltage on each inverter. If the voltage readings are similar across all inverters, verify that all battery cables are of equal length and made from the same material. If not, please reach out to your installer to obtain the standard operating procedure for calibrating the battery voltage on each inverter. If the issue persists, please contact your installer for further assistance.
VOL/FREQ different	AC input voltage and frequency are detected differently.	<ol style="list-style-type: none"> Verify the utility wiring connections and restart the inverter. Ensure that the utility power starts simultaneously. If there are breakers installed between the utility and the inverters, make sure all breakers can be switched on to allow AC input at the same time. If the issue persists, please contact your installer.

Output setting different	AC output mode setting is different.	<ol style="list-style-type: none">1. Switch off the inverter and check the LCD "Output mode setting".2. For a parallel system in single phase, make sure no 3P1, 3P2, or 3P3 is set on "Output mode setting". For supporting three-phase system, make sure no "PAL" is set on "Output mode setting".3. If the problem remains, please contact your installer.
--------------------------	--------------------------------------	---

Appendix II: BMS Communication Installation

1. Introduction

When connecting to a lithium battery, it is advisable to use a custom-made RJ45 communication cable. Please consult your dealer or integrator for more information.

This specially designed RJ45 communication cable transmits data and signals between the lithium battery and the inverter. The information it provides includes:

- Adjusting the charging voltage, charging current, and battery discharge cut-off voltage based on the lithium battery's specifications.
- Controlling the inverter to start or stop charging depending on the lithium battery's condition.

2. Pin Assignment for BMS Communication Port

	Definition
PIN 1	RS232TX
PIN 2	RS232RX
PIN 3	RS485B
PIN 4	NC
PIN 5	RS485A
PIN 6	CANH
PIN 7	CANL
PIN 8	GND

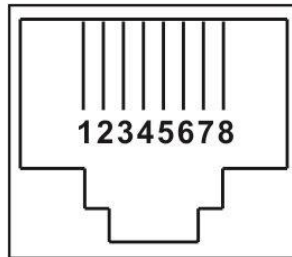

3. Lithium Battery Communication Configuration

LIO-4805/LIO-4810-150A

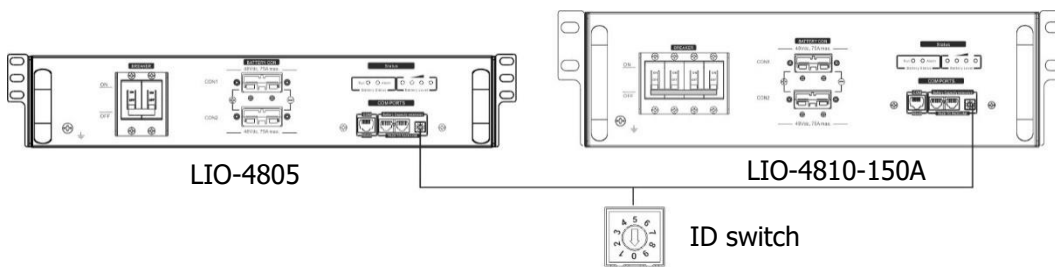

ESS II-4810

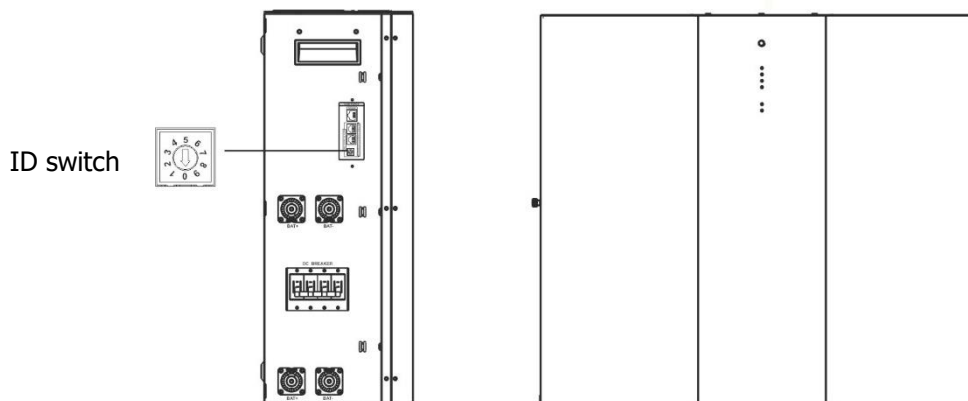

The ID Switch represents the unique identification code assigned to each battery module. To ensure proper functioning, each battery module must have a distinct ID. You can configure the ID code for each module by turning the PIN number on the ID switch. The numbers range from 0 to 9 and can be assigned in any order. Up to 10 battery modules can operate simultaneously in parallel.

4. Installation and Operation

LIO-4805/LIO-4810-150A/ESS II-4810

Once an ID number has been assigned to each battery module, please configure the LCD panel on the inverter and complete the wiring connections by following the steps below.

Step 1: Use the supplied RJ11 signal cable to connect to the extension port (P1 or P2).

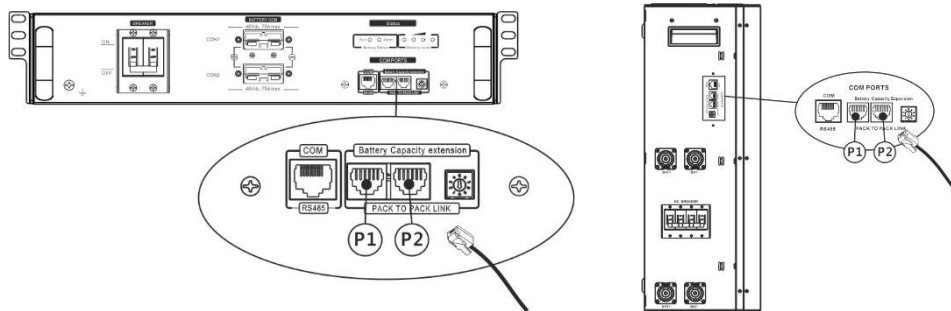

Step 2: Use the provided RJ45 cable (included in the battery module package) to connect the inverter to the lithium battery.

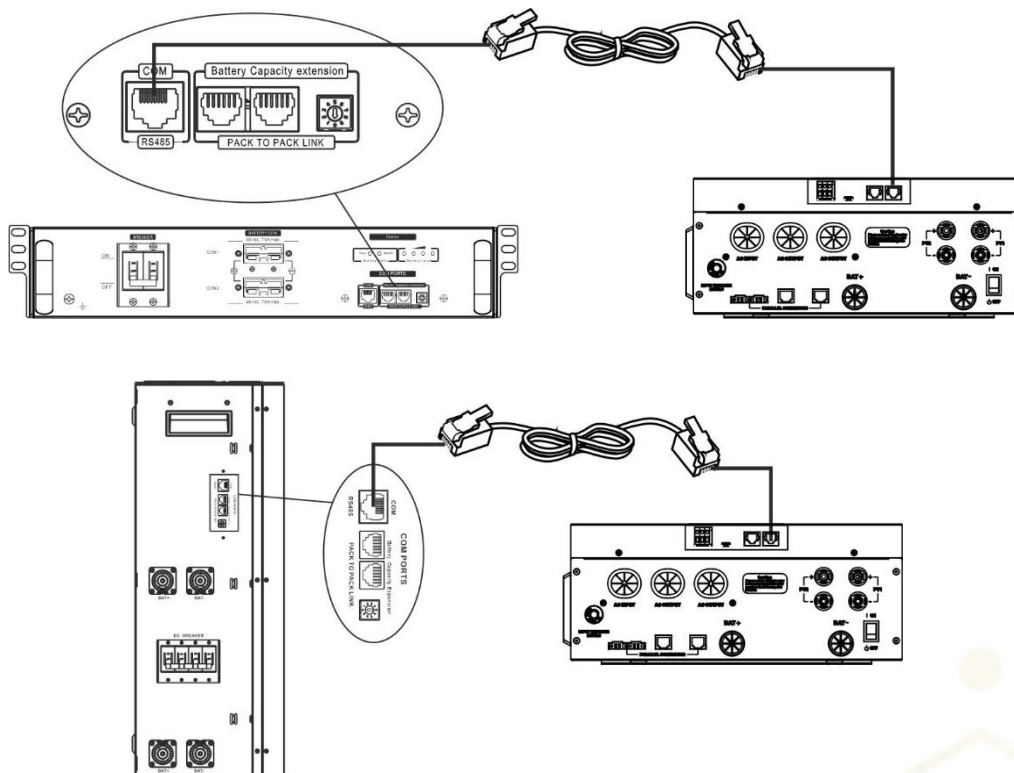

* For multiple battery connections, please check the battery manual for the details.

Note for parallel system:

1. Only support common battery installation.
2. Use a custom-made RJ45 cable to connect any inverter (no need to connect to a specific inverter) and Lithium battery. Simply set this inverter battery type to "LIB" in the LCD. Others should be "USE".

Step 3: Turn the breaker switch "ON". Now, the battery module is ready for DC output.



Step 4: Press the Power on/off button on the battery module for 5 secs, the battery module will start up.

*If the manual button cannot be approached, simply turn on the inverter module. The battery module will be automatically turned on.

Step 5: Turn on the inverter.

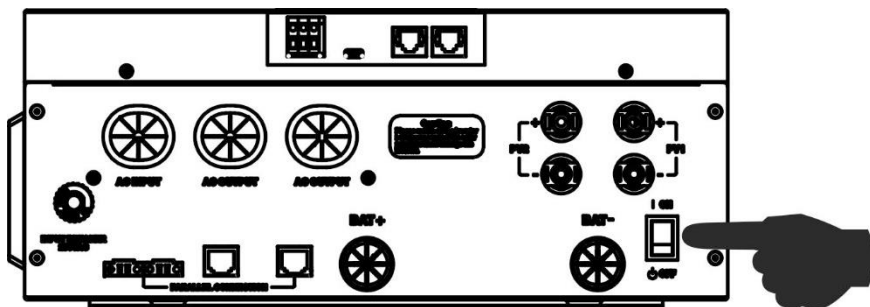

Step 6. Be sure to select battery type as "LIB" in battery Setting.

If communication between the inverter and battery is successful, the BMS icon will display.

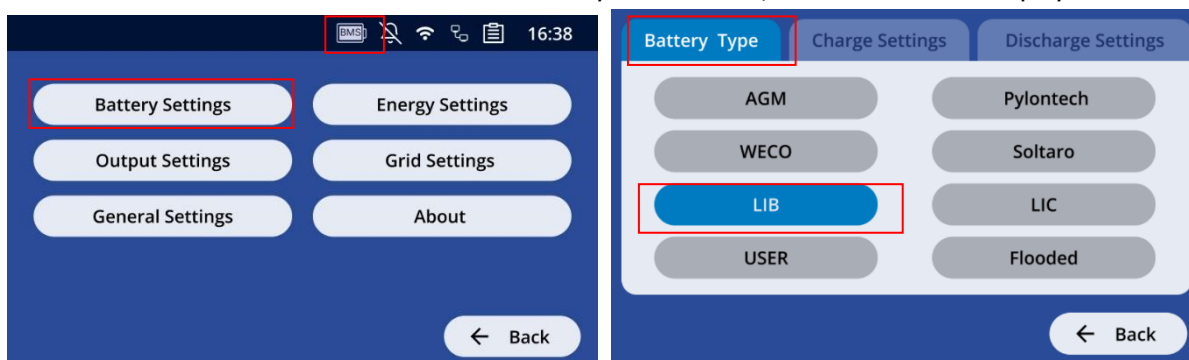

5. Code Reference

The relevant information code will be shown on the LCD screen. Please refer to the inverter's LCD screen for operation details.

Warning Code	Description
BMS communication failure	<p>Communication lost (this message appears only when the battery type is not set to "AGM," "Flooded," or "User-Defined").</p> <ul style="list-style-type: none"> If no communication signal is detected within 3 minutes after the battery is connected, the buzzer will sound. After 10 minutes, the inverter will stop charging and discharging the lithium battery. Communication loss happens immediately after the inverter and battery are successfully connected, causing the buzzer to beep right away.
BAT stop charge/discharge	If the battery is not permitted to charge or discharge after successful communication between the inverter and the battery.
Battery stop charging	If the battery status does not permit charging even after successful communication between the inverter and the battery.
Battery force charging	The battery status needs to be charged once the communication between the inverter and the battery is successfully established.
Battery stop discharging	If the battery is not permitted to discharge after successful communication between the inverter and the battery.

Appendix III: The CT Operation Guide

When connected with a CT, the solar inverter can be seamlessly integrated into the existing home system. The CT is used to manage self-consumption by controlling the inverter's power generation and battery charging. Please note that the CT must be purchased separately if needed.

1. Single commissioning

Step 1. Power off the inverter and attach the external current transformer (CT) using the provided tool accessory to the spring terminal block. Make sure the current flow direction mark on the CT is facing toward the inverter, and connect the CT wires to the terminal block following the correct polarity: the red wire to "L+" and the white wire to "L-".

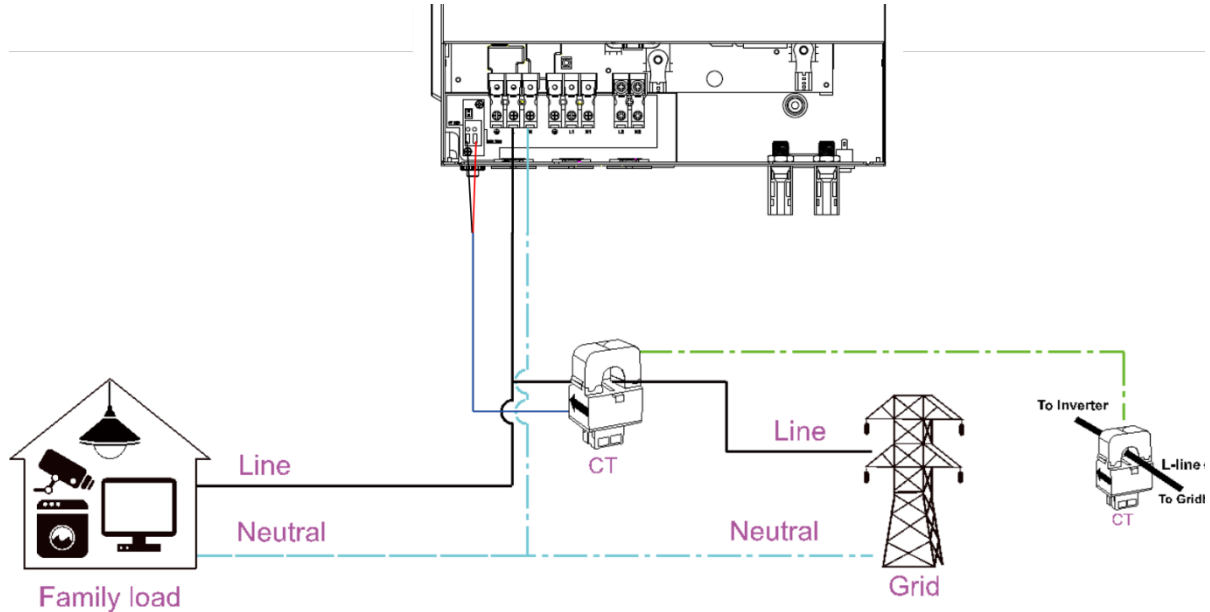

Step 2: Power on the inverter.

Step 3: Go to the Operation mode settings, choose the "Energy self-use" mode on the inverter that has the CT sensor connected, and activate the CT function by setting it to "enable."

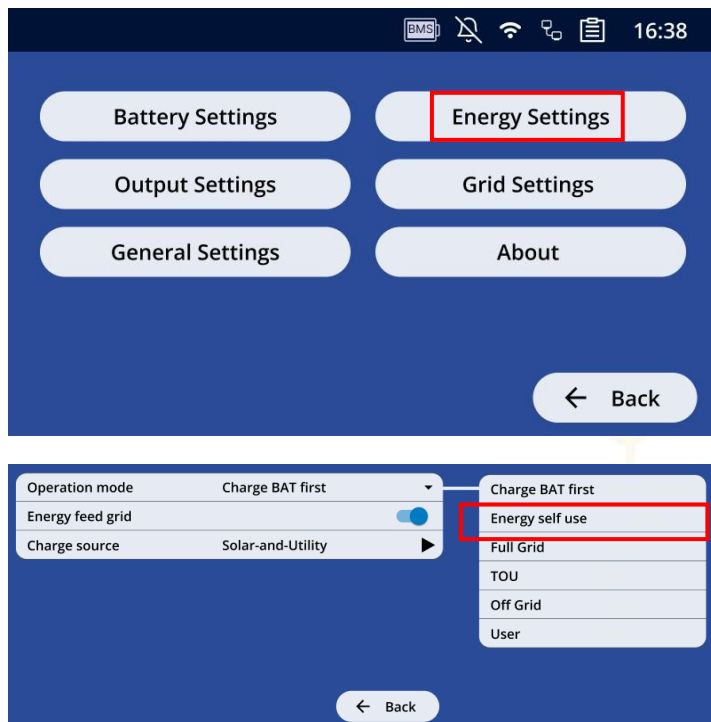

2. Parallel commissioning

Step 1. Power off the inverter and connect the CT sensor according to the wiring diagram below. For other parallel circuits, please follow Appendix I.

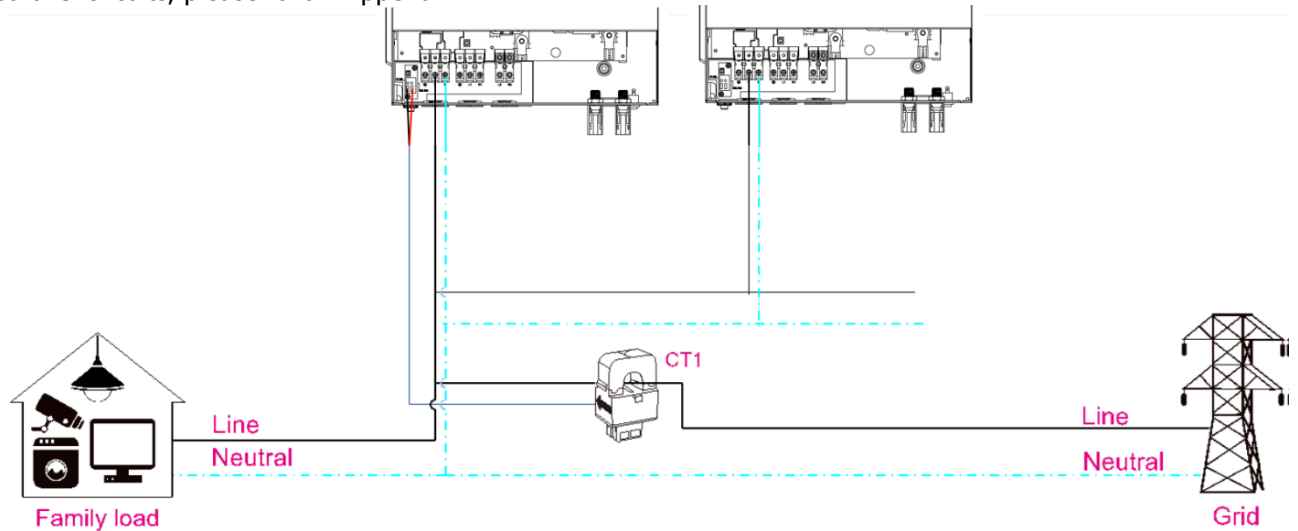

Step 2: Power on each inverter.

Step 3: Access the LCD settings on the inverter with the CT sensor connected, and activate the CT function by setting it to "enable." This is the same procedure as for the single-phase setting.

IMPORTANT ATTENTION:

When using the CT function in parallel operation, only one inverter in the parallel system needs to be connected to the CT sensor. Make sure to activate the #67 external CT function on the inverter connected to the CT, and set the other inverters to "Disable." If this is not done, the CT function will not work properly during parallel operation.

3. Three-phase commissioning

Step 1. Power off the inverter and connect the CT sensor according to the wiring diagram below. For other parallel circuits, please follow Appendix I.

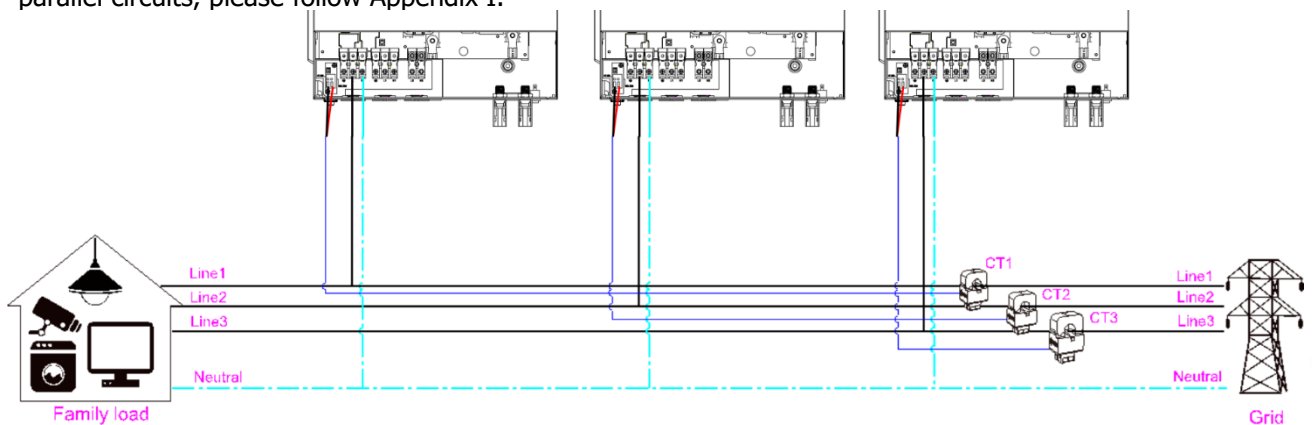

Step 2: Power on each inverter.

Step 3: Enter LCD settings on the inverter with the CT sensor connected and set the CT function to "enable". Same as a single-phase setting

IMPORTANT ATTENTION:

When using the CT function during three-phase operation, each phase must have one CT sensor connected to its inverter. Make sure to activate the #67 external CT function on the inverter with the CT connected, and set the other inverters for that phase to "Disable." Failing to do this will result in the CT function not working properly during parallel operation.

Appendix III: The Wi-Fi Operation Guide

1. Introduction

MOTOMA is an energy storage system monitoring APP provided by Shenzhen Motoma Power Co., Ltd. The APP displays the current running status and data changes of the energy storage system in real time in charts, energy flow charts, lists and other ways.

The main features of the software are:

- The current running status and detailed data of the energy storage system are displayed in real time by charts, energy flow charts, and lists.
- Real-time data and historical data can be queried in time to master the operation status of the energy storage system anytime and anywhere.
- The Chinese and English interfaces are free to switch with the operating system language of the handheld device.



2. "MOTOMA" App

2-1. Download and install APP

Operating system requirement for your smart phone:

🍏 iOS system supports iOS 9.0 and above

🤖 Android system supports Android 5.0 and above

Please scan the following QR code with your smart phone and download "**MOTOMA**" App.



Android system



iOS system

Or you may find "**MOTOMA**" App from the Apple® Store.



2-2. Initial Setup

Step 1: Registration at first time

After the installation, please tap the shortcut icon  to access this APP on your mobile screen. In the screen, tap "Register" to access "User Registration" page. You can register by entering PN number, user name, password, email address, and mobile phone number. After the registration is successful, you can return to the login page to log in.

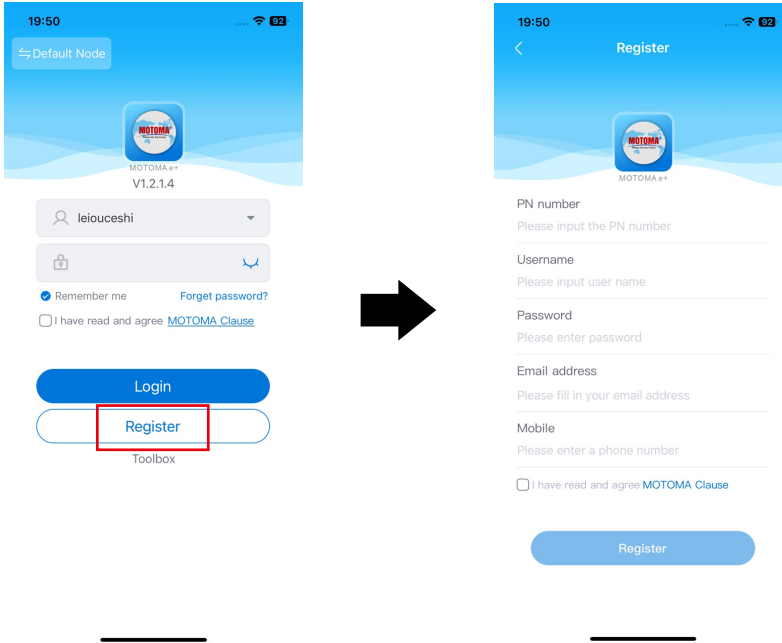

2-3. Equipment Distribution Network

● Network access

Entry 1: Login Page-toolbox-Wi-Fi distribution network"

Entry 2: Click "my" interface " → " Wi-Fi distribution network"

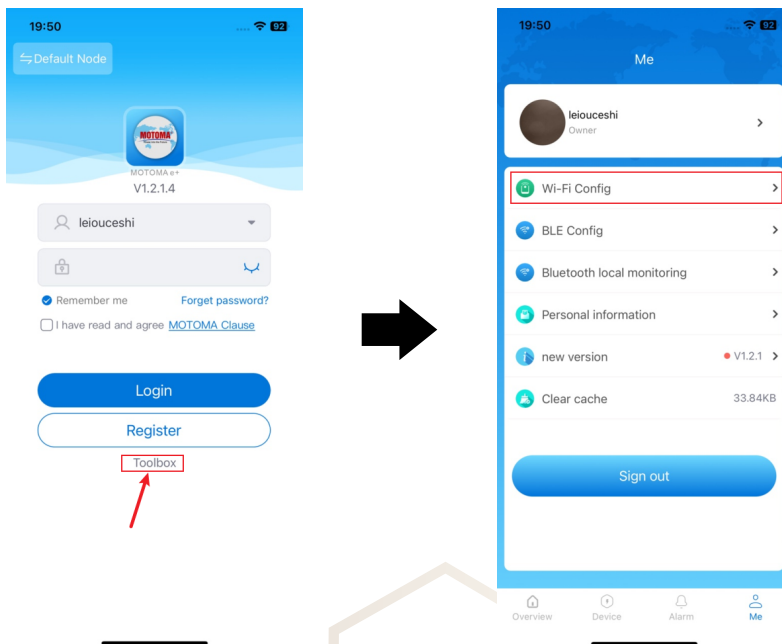

● Wi-Fi network distribution process

Step 1: connect the device

Open the "Wi-Fi" in the "Settings" of the mobile phone, connect the digital collector PN that needs to be allocated to the network, open the optical treasure APP, click the "toolbox", select the Wi-Fi distribution network to enter the distribution network page, click the "networking settings" to select the Wi-Fi and enter the password to connect.

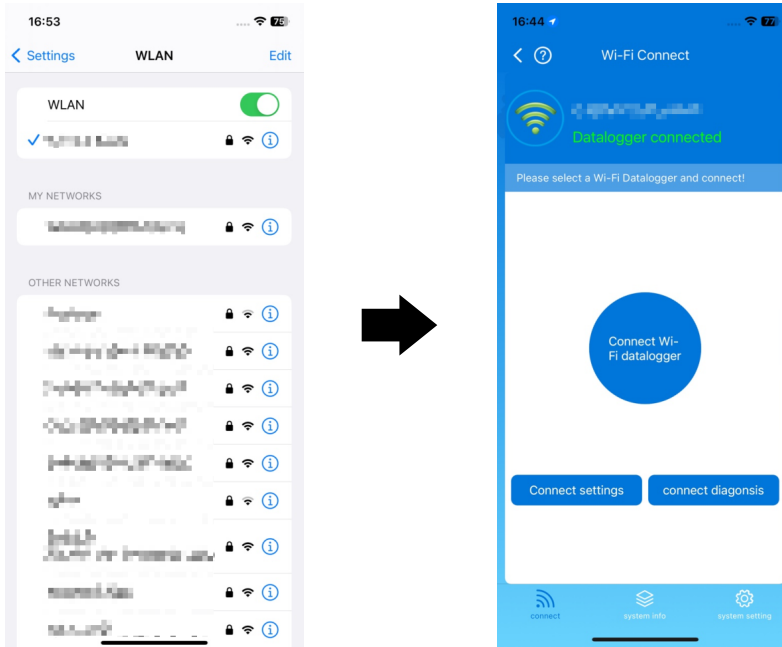

Step 2: configure a network for the device

Enter the router name and password, or click the signal icon to view the nearby Wi-Fi network.

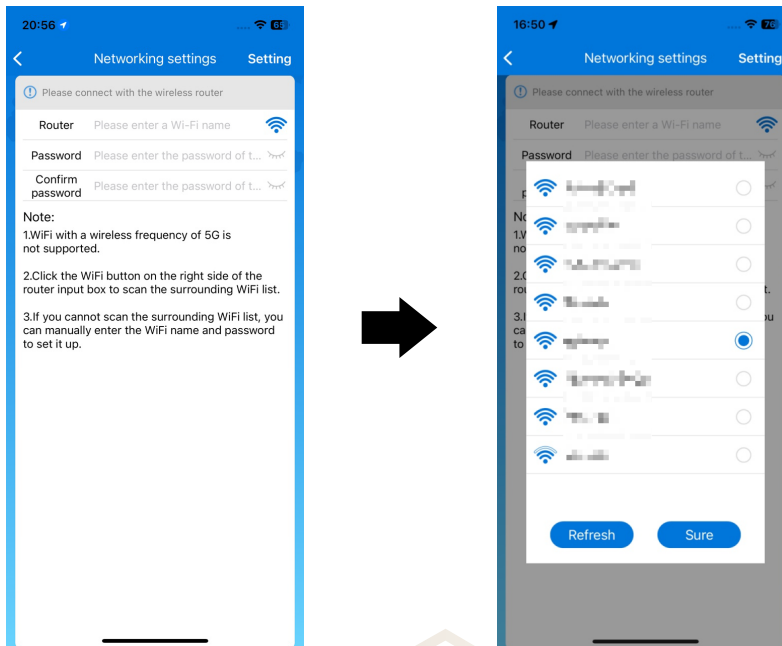

Note:

1. Please ensure that the signal connected to the network is good and the network is unblocked.
2. Currently, routers in 5G band are not supported. Please use routers in 2.4G Band.
3. Make sure that the router password is correct.

Step 3: view the distribution results

If the network configuration is successful, the datalogger restarts.
After about 5 minutes, you can see the device data.

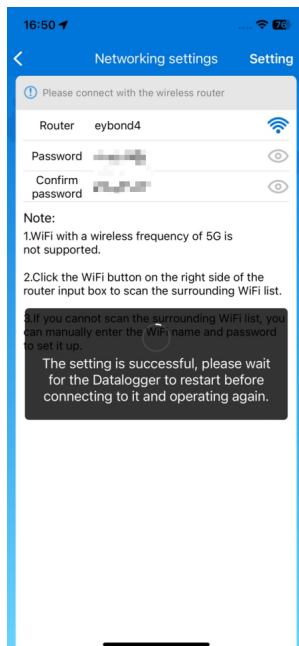

2-4. Login

After finishing the registration and local Wi-Fi configuration, enter registered name and password to login.
Note: Tick "Remember Me" for your login convenience afterwards.

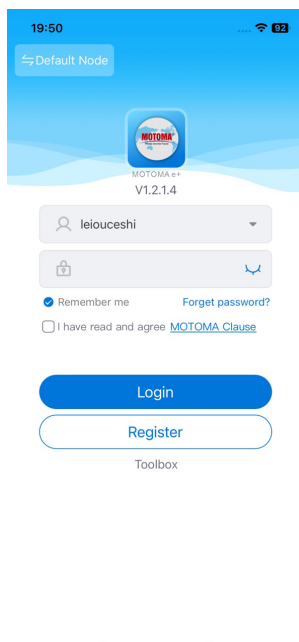

3. APP Main Function

3-1. Overview

Show all devices under the account, view the device status, current day earnings, current month earnings, current year earnings, PV current power, total CO₂ emission reduction, and daily, monthly, and annual power generation, and display the chart.

- Blue indicates that the device is normal;
- Gray indicates that the device is offline;
- Red indicates equipment failure;
- Yellow indicates device alerts;
- Cyan indicates that the device is standby.

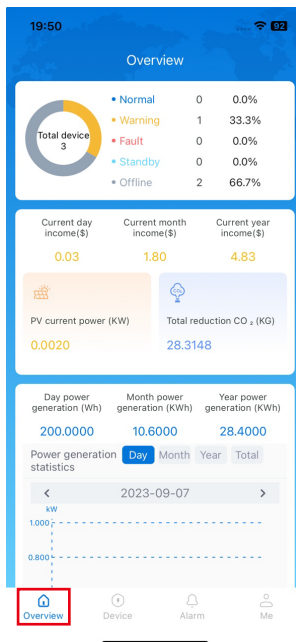

3-2. Device

Device List

Displays all devices under the account, and displays the status and basic parameters of the devices.

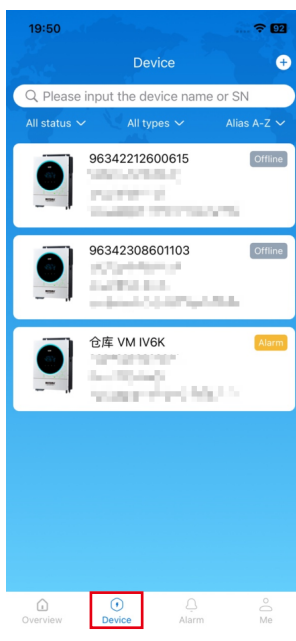

Add device

Step 1: Entry

On the devices page, click the Add + icon.

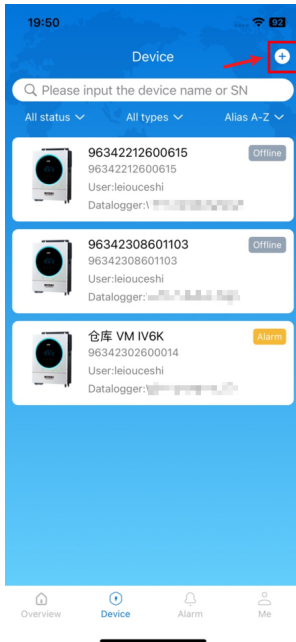

Step 2: Add a device

Complete the device information to add the device successfully.

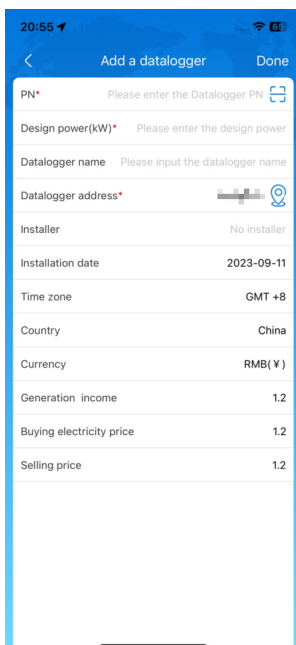

Step 3: Add successfully

After the device is added, if the device does not have a network, data cannot be migrated to the cloud. If it is a WiFi device, you need to configure a network for the device.

Device Details

1. Energy flow diagram

You can view the energy status and parameters of the equipment. Click the solar inverter, power grid, and battery icons to view the relevant parameters of the equipment.

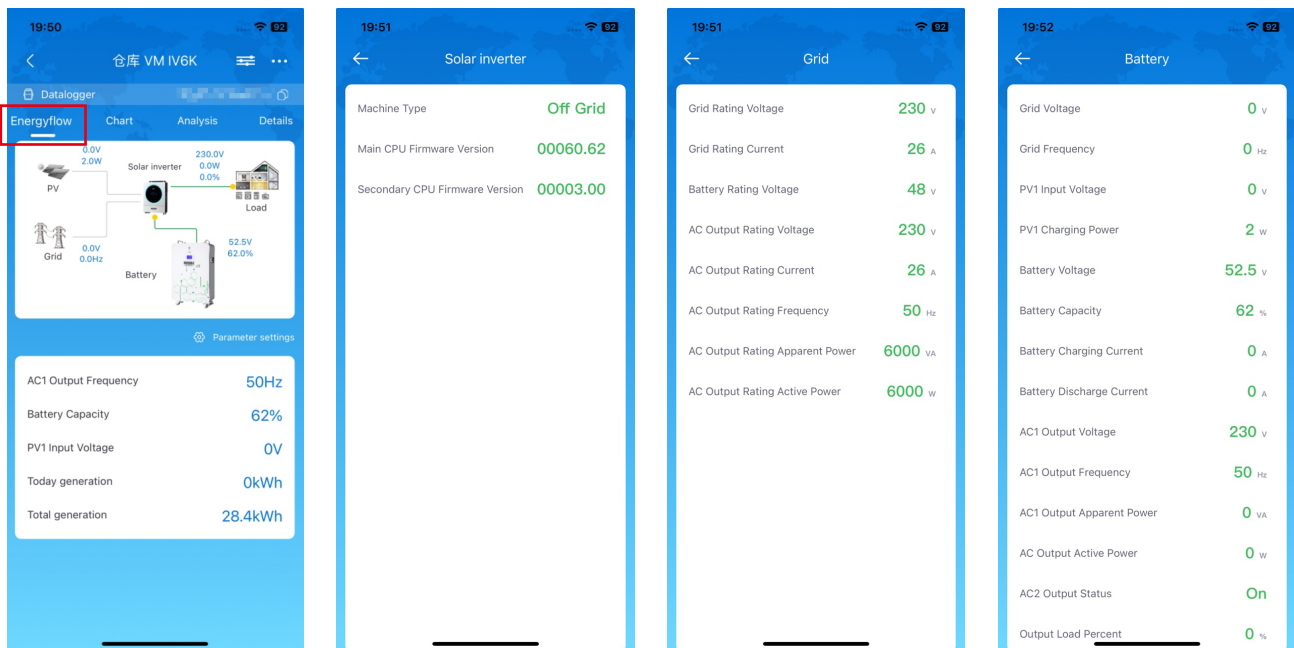

2. Data charts

You can view the area diagram of the power generation and load power of the equipment, and the column diagram of the monthly, annual and total power generation.

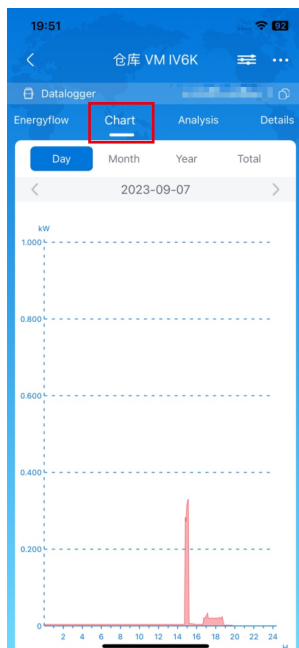

3. Parameter settings

You can Gou Xuan parameters by setting parameters. The Gou Xuan parameters are displayed directly, which is convenient for you to view some important parameters. Click reset to clear all Gou Xuan.

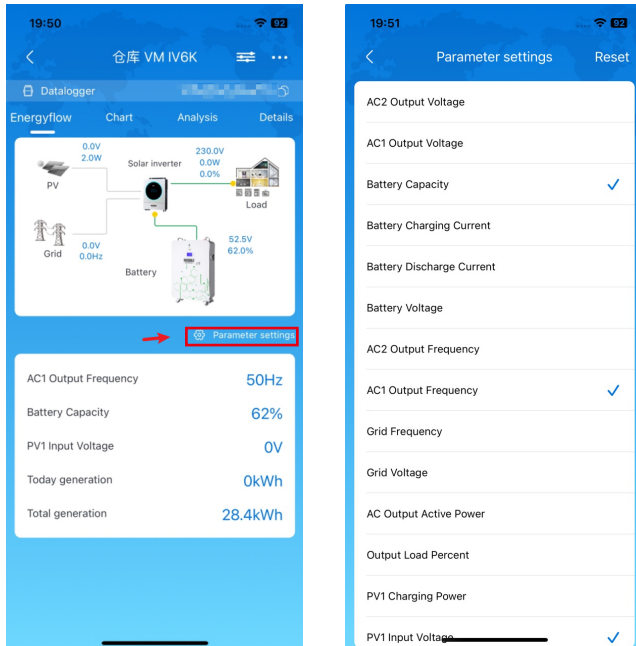

4. Parameter Analysis

You can select a parameter of the device for analysis.

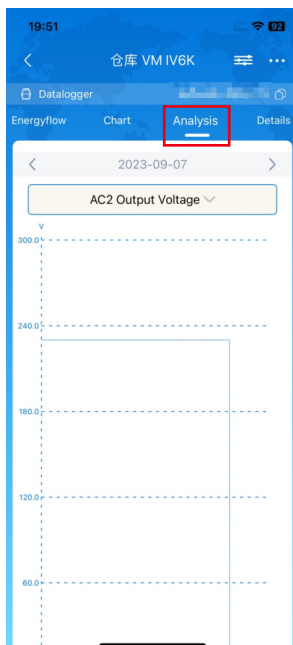

5. Data details

You can view the data details recorded by the device every five minutes.

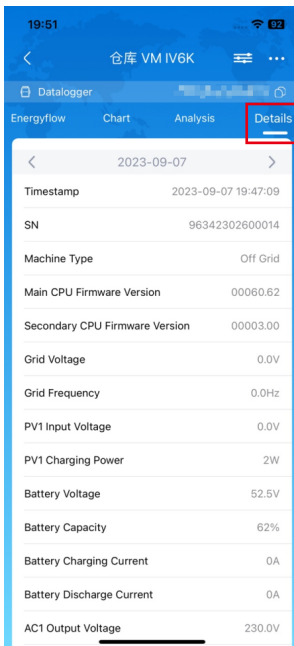

6. Equipment Control

This page is to activate some features and set up parameters for inverters. Please be noted that the listing in "Parameter Setting" page in below diagram may differ from the models of monitored inverter. Here will briefly highlight some of it, **【Output Setting】** , **【Battery Parameter Setting】** , **【Enable/ Disable items】** , **【Restore to the defaults】** to illustrate.

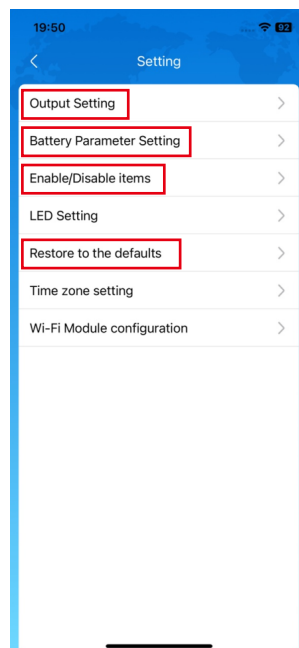
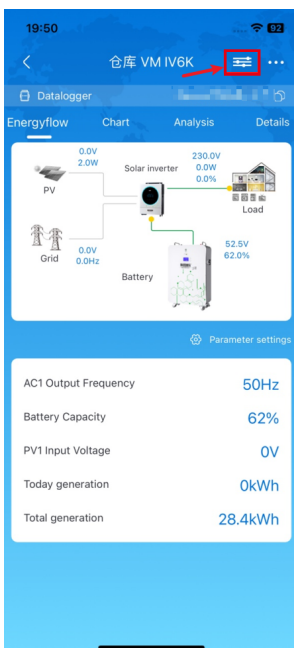

There are three ways to modify setting and they vary according to each parameter.

- Listing options to change values by tapping one of it.
 - Activate/Shut down functions by clicking "Enable" or "Disable" button.
 - Changing values by clicking arrows or entering the numbers directly in the column.
- Each function setting is saved by clicking "Set" button.

Please refer to below parameter setting list for an overall description and be noted that the available parameters may vary depending on different models. Please always see the original product manual for detailed setting instructions.

Parameter setting list:

Item		Description
Output setting	Output source priority	To configure load power source priority.
	AC input range	When selecting "UPS", it's allowed to connect personal computer. Please check product manual for details.
		When selecting "Appliance", it's allowed to connect home appliances.
	Output voltage	To set output voltage.
	Output frequency	To set output frequency.
Battery parameter setting	Battery type:	To set connected battery type.
	Battery cut-off voltage/SOC	To set the battery stop discharging voltage or SOC. Please see product manual for the recommended voltage or SOC range based on connected battery type.
	Back to grid voltage/SOC	When "SBU" or "SOL" is set as output source priority and battery voltage is lower than this setting voltage or SOC, unit will transfer to line mode and the grid will provide power to load.
	Back to discharge voltage/SOC	When "SBU" or "SOL" is set as output source priority and battery voltage is higher than this setting voltage or SOC, battery will be allowed to discharge.
	Charger source priority:	To configure charger source priority.
Item		Description
Battery parameter setting	Max. charging current	It's to set up battery charging parameters. The selectable values in different inverter model may vary. Please see product manual for the details.
	Max. AC charging current:	
	Float charging voltage	
	Bulk charging voltage	It's to set up battery charging parameters. The selectable values in different inverter model may vary. Please see product manual for the details.
	Battery equalization	Enable or disable battery equalization function.
	Real-time Activate Battery Equalization	It's real-time action to activate battery equalization.
	Equalized Time Out	To set up the duration time for battery equalization.
	Equalized Time	To set up the extended time to continue battery equalization.
	Equalization Period	To set up the frequency for battery equalization.
	Equalization Voltage	To set up the battery equalization voltage.
Enable/Disable Functions	LCD Auto-return to Main screen	If enable, LCD screen will return to its main screen after one minute automatically.
	Fault Code Record	If enabled, fault code will be recorded in the inverter when any fault happens.
	Backlight	If disabled, LCD backlight will be off when panel button is not operated for 1 minute.
	Bypass Function	If enabled, unit will transfer to line mode when overload happened in battery mode.
	Beeps while primary source interrupt	If enabled, buzzer will alarm when primary source is abnormal.

Enable/Disable Functions	Over Temperature Auto Restart	If disabled, the unit won't be restarted after over-temperature fault is solved.
	Overload Auto Restart	If disabled, the unit won't be restarted after overload occurs.
	Buzzer	If disabled, buzzer won't be on when alarm/fault occurred.
Restore to the default	This function is to restore all settings back to default settings.	

7. Delete the device

After a device is deleted, the device is not displayed in the device list.

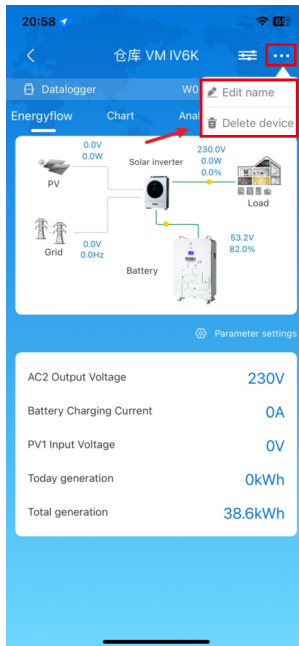

8. View the number of collectors

You can view the information of the Digital Collector and Digital Collector connected to the device.

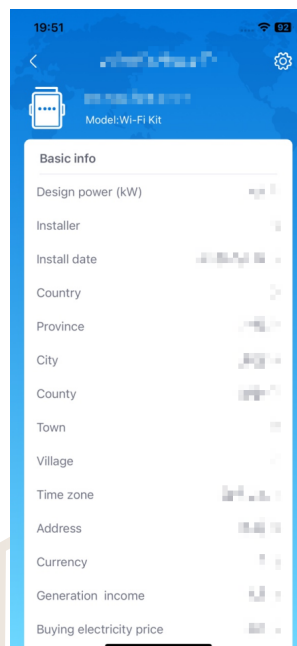
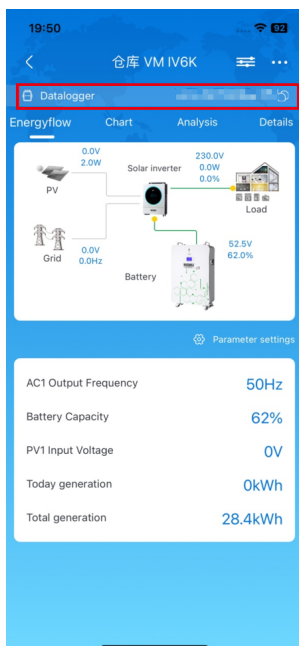

9. Datalogger details

You can view the information of the datalogger and perform operations such as restarting, debugging, and deleting the datalogger.

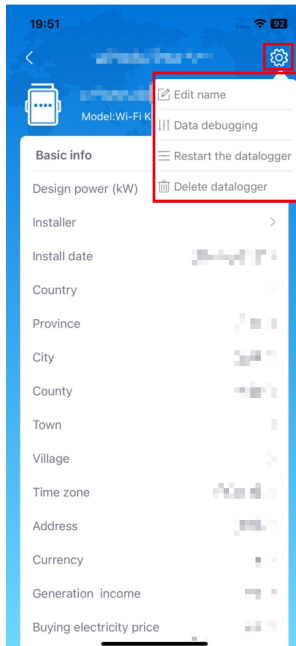

3-3. Alarm

Alarm List

Displays all Alarm information under the current account. You can filter alarm information by date, alarm status, and alarm type.

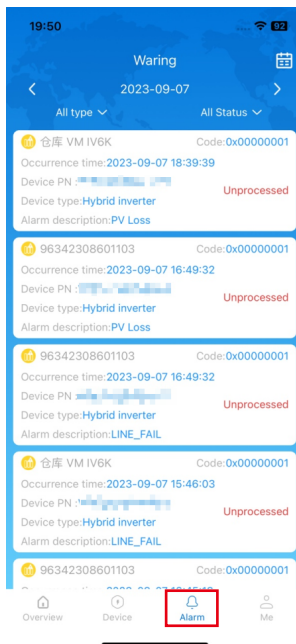

3-4. Me

Change Avatar

Click the avatar to select a mobile phone photo or a photo to change the avatar.

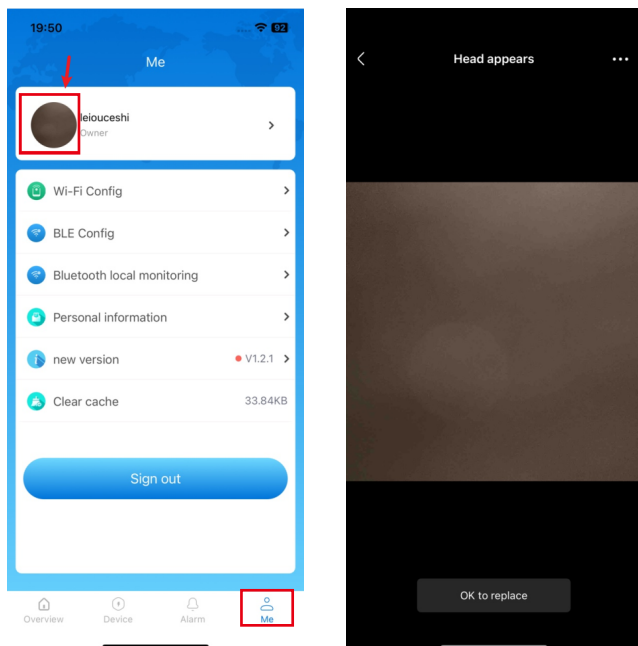

Username

You can click the user name to enter the personal information page. You can modify personal information such as nicknames and passwords.

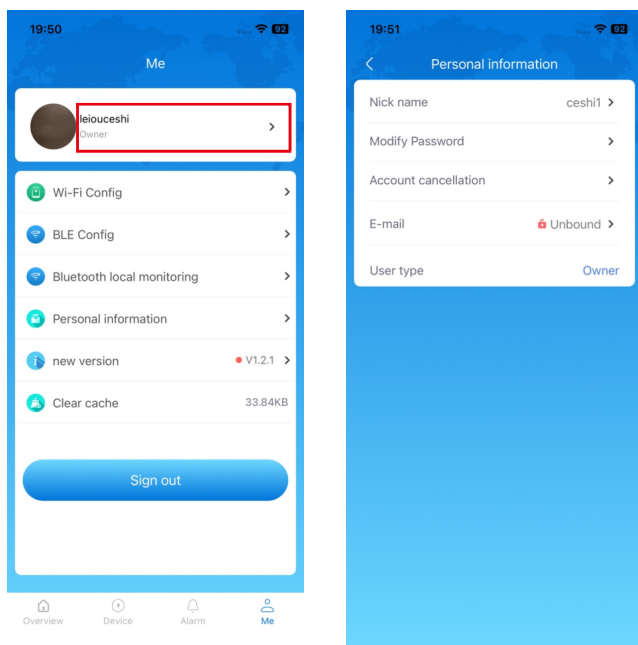

Version Update

After a new version is released, click Update to go to the mall to update the APP.

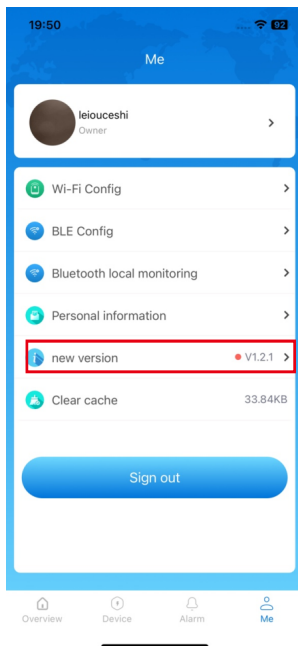

Clear Cache

Click Clear cache to clear the APP cache.

